

Instructions

95-8554

IR Flame Detector
X9800



Table Of Contents

DESCRIPTION	1
Outputs	1
LED	2
Optical Integrity (Oi)	2
Communication	3
Data Logging / Event Monitoring.....	3
Integral Wiring Compartment	3
SIGNAL PROCESSING OPTIONS	3
GENERAL APPLICATION INFORMATION	4
Response Characteristics	4
Welding	4
Artificial Lighting	4
EMI / RFI Interference.....	4
Non-carbon Fires	4
False Alarm Sources.....	4
Factors Inhibiting Detector Response.....	5
IMPORTANT SAFETY NOTES	5
INSTALLATION.....	6
Detector Positioning.....	6
Detector Orientation.....	6
Wire Size and Type.....	7
Protection Against Moisture Damage	7
Wiring Procedure	7
EOL Resistors.....	8
STARTUP PROCEDURE	10
Fire Alarm Test.....	10
TROUBLESHOOTING.....	11
Periodic Checkout Procedure	11
MAINTENANCE.....	11
Cleaning Procedure	11
Oi Plate Removal	12
Clock Battery.....	12
FEATURES.....	12
SPECIFICATIONS	13
REPLACEMENT PARTS	14
DEVICE REPAIR AND RETURN.....	14
ORDERING INFORMATION	15
Accessories.....	15
Replacement Parts	15
APPENDIX.....	16

AUTOMATIC
oi***IR Flame Detector
X9800****IMPORTANT**

Be sure to read and understand the entire instruction manual before installing or operating the flame detection system.

ATTENTION

*The X9800 includes the Automatic Optical Integrity (oi) feature — a calibrated performance test that is automatically performed once per minute to verify complete detector operation capabilities. **No testing with an external test lamp is required.***

**DESCRIPTION**

The evolution continues with the new X9800 IR Flame Detector. The X9800 meets the most stringent requirements worldwide with advanced detection capabilities and immunity to extraneous sources, combined with a superior mechanical design. The detector is equipped with both automatic and manual **oi** test capability. The detector has Division and Zone explosion-proof ratings and is suitable for use in indoor and outdoor applications.

The standard output configuration includes fire, fault and auxiliary relays. An optional 4 to 20 mA output can be provided in addition to the three relays. A multi-color LED on the detector faceplate indicates detector status condition.

The X9800 housing is available in copper-free aluminum or stainless steel, both with NEMA 4X and IP66 rating.

***oi** is Detector Electronics' Trademark for its patented Optical Integrity Systems, U.S. Patent 3,952,196, United Kingdom Patent 1,534,969, Canada Patent 1,059,598.

OUTPUTS**Relays**

The standard detector is furnished with fire, fault and auxiliary relays. All three relays are rated 5 amperes at 30 VDC.

The Fire Alarm relay has redundant terminals and normally open / normally closed contacts, normally de-energized operation, and latching or non-latching operation.

The Fault relay has redundant terminals and normally open contacts, normally energized operation, and latching or non-latching operation.

The Auxiliary relay has normally open / normally closed contacts, normally energized operation, and latching or non-latching operation.

Table 1—Detector Status Conditions Indicated by Current Level

Current Level (±0.5 mA)	Detector Status
0 mA	Open Circuit
1 mA	General Fault
2 mA	Oi Fault
4 mA	Normal Operation
16 mA	Pre-Alarm
20 mA	Fire Alarm

4 to 20 mA Output

A 4 to 20 mA output is available as an option (in addition to the three relays). This option provides a 4 to 20 mA dc current output for transmitting detector status information to other devices. The circuit can be wired in either an isolated or non-isolated configuration and can drive a maximum loop resistance of 500 ohms from 18 to 19.9 volts dc and 600 ohms from 20 to 30 volts dc. Table 1 indicates the detector status conditions represented by the various current levels. The output is calibrated at the factory, with no need for field calibration.

NOTE

The output of the 4 to 20 mA current loop is not monitored by the fault detection circuitry of the X9800. Therefore, an open circuit on the loop will not cause the fault relay to change state or the detector status LED to indicate a fault. The status of the LED always follows the status of the relays.

LED

A tricolor LED on the detector faceplate indicates normal, fire alarm and fault conditions. Table 2 indicates the condition of the LED for each status.

OPTICAL INTEGRITY (Oi)

Automatic oi

The X9800 includes the Automatic Optical Integrity (oi) feature — a calibrated performance test that is automatically performed once per minute to verify complete detector operation capabilities. No testing with an external test lamp is required. The detector automatically performs the same test that a maintenance person with a test lamp would perform — once every minute, 60 times per hour. However, a successful automatic oi test does not produce an alarm condition.

The X9800 signals a fault condition when less than half of the detection range remains. This is indicated by the Fault relay and is evident by the amber color of the LED on the face of the detector. See the "Troubleshooting" section for further information.

Magnetic oi / Manual oi

The detector also incorporates both magnetic oi and manual oi features that provide the same calibrated test as the automatic oi, and in addition actuates the Alarm relay to verify output operation for preventive maintenance requirements. These features can be performed at any time and eliminate the need for testing with a non-calibrated external test lamp.

CAUTION

These tests require bypass of all extinguishing devices to avoid release resulting from a successful test.

Table 2—Detector Status Indicator

Detector Status	LED Indicator
Power On/Normal Auto Oi (no fault or fire alarm)	Green
Power On/Normal Man Oi	Green, flashing on for 0.5 sec. every 5 sec.
Fault	Amber
Pre-Alarm/Background IR	Red, flashing on for 500 ms. and off for 500 ms.
Fire (Alarm)	Steady Red
On Power-Up, The LED Flashes in Sequence as Follows, Indicating Sensitivity and Signal Processing Status	
Low IR Sensitivity Medium IR Sensitivity High IR Sensitivity Very High IR Sensitivity	One Green Flash Two Green Flashes Three Green Flashes Four Green Flashes
Quick Fire / TDSA IR Signal TDSA only IR Signal	One Amber Flash Two Amber Flashes

The magnetic **oi** test is performed by placing a magnet by the marked location (mag **oi**) on the outside of the detector. The manual **oi** test is accomplished by connecting the **oi** lead (terminal 22) to power supply minus via an external switch. The magnet or switch must be held in place for a minimum of 6 seconds to complete the test. Either of these test methods activates the calibrated IR emitter. If the resulting signal meets the test criteria, indicating that greater than half of the detection range remains, the Alarm relay changes state, the indicating LED changes to red, and the 4-20 mA current output goes to 20 mA. This condition remains until the magnet is removed or the switch is released. If the alarm relay is configured for non-latching operation, it will change states and the red LED will turn to green. If the unit has latching relays, they can be reset by removing input power (0.1 second minimum) or by momentarily applying the magnet or manual **oi** switch.

If less than half of the detection range remains, no alarm is produced and a fault is generated. The fault indication can be reset by momentarily applying the magnet or manual **oi** switch.

NOTE

Refer to the Appendix for FM verification of Det-Tronics' patented Optical Integrity oi™ function.

COMMUNICATION

The X9800 is furnished with an RS-485 interface for communicating detector status and other information with external devices. The RS-485 uses MODBUS protocol, with devices configured as slaves.

DATA LOGGING / EVENT MONITORING

Data logging for event monitoring capability is also provided. The detector can log up to 1500 events (up to 1000 general and 500 alarm events). Status conditions such as normal, power down, general and **oi** faults, pre-alarm, fire alarm, time and temperature are recorded. Each event is time and date stamped, along with the temperature and input voltage. Event data is stored in non-volatile memory when the event becomes active, and again when the status changes. Data is accessible using the RS-485 port.

INTEGRAL WIRING COMPARTMENT

All external wiring to the device is connected within the integral junction box. The screw terminals accept wiring from 12 to 22 AWG. The detector is furnished with four conduit entries, with either 3/4 inch NPT or 25 mm threads.

SIGNAL PROCESSING OPTIONS

The X9800 features signal processing options. These options determine the type of logic that the detector will use for processing fire signals to customize the X9800 to the application. Two signal processing options are available for the X9800:

- TDSA enabled
- Both TDSA and Quick Fire enabled (either initiates fire alarm).

Time Domain Signal Analysis (TDSA)

The TDSA signal processing technique analyzes the input signal in real time, requiring the IR signal to flicker randomly in order to recognize it as a fire condition.

Using TDSA signal processing, the X9800 ignores regularly chopped blackbody sources (occurring in areas where moving conveyors and hot objects in proximity to one another result in a regularly chopped IR signal), because it looks for a less uniform signal. However, in the presence of a regularly chopped signal, the unit is more susceptible to false alarms due to sporadic IR that functions as a trigger when occurring in conjunction with the regularly chopped signal.

Quick Fire (High Speed)

The Quick Fire (High Speed) feature can be used in conjunction with the TDSA signal processing method. This method overrides TDSA requirements in the event of an intense signal. When Quick Fire is activated, the detector is capable of responding to an intense fire signal in less than 30 milliseconds (0.030 seconds). Using the Quick Fire feature in conjunction with TDSA signal processing allows the detector to provide a high speed response to a large, non-flickering fire (such as in high pressure gas applications) while maintaining an ability to respond to smaller fires.

GENERAL APPLICATION INFORMATION

RESPONSE CHARACTERISTICS

Response is dependent on distance, type of fuel, temperature of the fuel, and time required for the fire to come to equilibrium. As with all fire tests, results must be interpreted according to an individual application.

See Appendix A for fire test results.

WELDING

It is recommended that the system be bypassed during welding operations in situations where the possibility of a false alarm cannot be tolerated. Gas welding mandates system bypass, since the gas torch is an actual fire. Arc welding rods can contain organic binder materials in the flux that burn during the welding operation and are detectable by the X9800. Welding rods with clay binders do not burn and will not be detected by the X9800. However, system bypass is always recommended, since the material being welded may be contaminated with organic substances (paint, oil, etc.) that will burn and possibly trigger the X9800.

ARTIFICIAL LIGHTING

The X9800 should not be located within 3 feet of artificial lights. Excess heating of the detector could occur due to heat radiating from the lights.

EMI/RFI INTERFERENCE

The X9800 is resistant to interference by EMI and RFI, and is EMC Directive compliant and CE marked. It will not respond to a 5 watt walkie-talkie at distances greater than 1 foot.

NON-CARBON FIRES

The response of the X9800 is limited to carbonaceous fuels. It should not be used to detect fires from fuels that do not contain carbon, such as hydrogen, sulfur and burning metals.

FALSE ALARM SOURCES

The detector has been designed to ignore steady state infrared sources that do not have a flicker frequency characteristic of a fire, however, it should be noted that if these steady state infrared sources are hot enough to emit adequate amounts of infrared radiation in the response range of the IR sensor and if this radiation becomes interrupted from the view of the detector in a pattern characteristic of a flickering flame, the IR sensor can respond.

Any object having a temperature greater than 0° Kelvin (-273°C) emits infrared radiation. The hotter the object, the greater the intensity of the emitted radiation. The closer the infrared source is to the detector, the greater the potential for a false alarm. The IR sensor can respond to IR radiation sources that can meet the amplitude and flicker requirements of the detector such as vibrating hot objects.

FACTORS INHIBITING DETECTOR RESPONSE

Windows

Glass and Plexiglas windows significantly attenuate radiation and must not be located between the detector and a potential flame source. If the window cannot be eliminated or the detector location changed, contact Detector Electronics for recommendations regarding window materials that will not attenuate radiation.

Obstructions

Radiation must be able to reach the detector in order for it to respond. Care must be taken to keep physical obstructions out of the line of view of the detector.

Smoke

Smoke will absorb radiation. If accumulations of dense smoke can be expected to precede the presence of a flame, then detectors that are used in enclosed areas should be mounted on the wall approximately 3 feet (1 meter) from the ceiling where the accumulation of smoke is reduced.

Detector Viewing Windows

It is important to keep the detector viewing windows as free of contaminants as possible in order to maintain maximum sensitivity. Commonly encountered substances that can significantly attenuate IR radiation include, but are certainly not limited to, the following:

- Dust and dirt buildup
- Paint overspray
- Water and ice.

IMPORTANT SAFETY NOTES

WARNING

Do not open the detector assembly in a hazardous area when power is applied. The detector contains limited serviceable components and should never be opened. Doing so could disturb critical optical alignment and calibration parameters, possibly causing serious damage. This type of damage could be undetected and could result in failure to see a fire and/or false alarm.

CAUTION

The wiring procedures in this manual are intended to ensure proper functioning of the device under normal conditions. However, because of the many variations in wiring codes and regulations, total compliance to these ordinances cannot be guaranteed. Be certain that all wiring complies with the NEC as well as all local ordinances. If in doubt, consult the authority having jurisdiction before wiring the system. Installation must be done by a properly trained person.

CAUTION

To prevent unwanted actuation or alarm, extinguishing devices must be disconnected prior to performing detection system tests or maintenance.

ATTENTION

Remove the protective cap from the front of the detector before activating the system.

ATTENTION

Observe precautions for handling electrostatic sensitive devices.

INSTALLATION

NOTE

The recommended lubricant for threads and O-rings is a silicone free grease (part number 005003-001) available from Detector Electronics. Under no circumstances should a lubricant containing silicone be used.

DETECTOR POSITIONING

Detectors should be positioned to provide the best unobstructed view of the area to be protected. The following factors should also be taken into consideration:

- Identify all high risk fire ignition sources.
- Be sure that enough detectors are used to adequately cover the hazardous area.
- Locate and position the detector so that the fire hazard(s) are within both the field of view and detection range of the device. Refer to Appendix A for specific information.
- Be sure that the unit is easily accessible for cleaning and other periodic servicing.
- The detector should be aimed downward at least 10 to 20 degrees to allow lens openings to drain. See Figure 1. **The detector should be positioned so that its field of view does not cover areas outside the hazardous area.** This will minimize the possibility of false alarms caused by activities outside the area requiring protection.
- For best performance, the detector should be mounted on a rigid surface in a low vibration area.
- Dense fog, rain as well as certain gases and vapors can absorb IR radiation and reduce the sensitivity of the detector.
- Verify that all detectors in the system are properly aimed at the area to be protected. (The Det-Tronics Q1201C Laser Aimer is recommended for this purpose.)
- If possible, fire tests should be conducted to verify correct detector positioning and coverage.

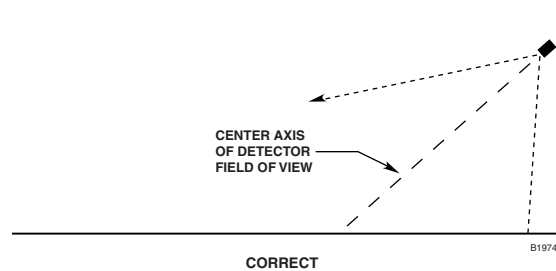
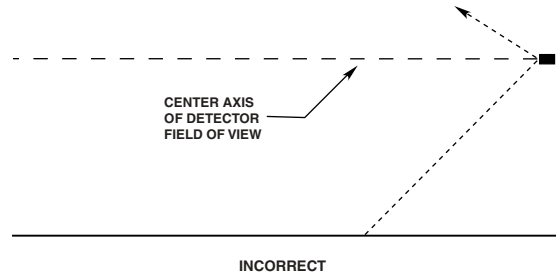

NOTE: DETECTOR MUST ALWAYS BE AIMED DOWNWARD AT LEAST 10 TO 20 DEGREES.

Figure 1—Detector Orientation Relative to Horizon

DETECTOR ORIENTATION

Refer to Figure 2 and ensure that the **oi** plate will be oriented as shown when the X9800 is mounted and sighted. This will ensure proper operation of the **oi** system and will also minimize the accumulation of moisture and contaminants between the **oi** plate and the viewing windows.

IMPORTANT

The **oi plate must be securely tightened to ensure proper operation of the **oi** system (40 oz./inches recommended).**

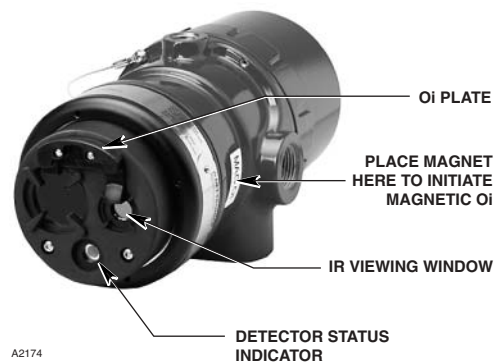

Figure 2—Front View of the X9800

WIRE SIZE AND TYPE

The system should be wired using a 12 to 22 gauge (2.5 to 0.3 mm²) cable. The wire size selected should be based on the number of detectors connected, the supply voltage and the cable length. A minimum input voltage of 18 vdc must be present at the X9800.

The use of shielded cable is required to protect against interference caused by EMI and RFI. When using cables with shields, terminate the shields as shown in Figures 7 through 12. Consult the factory if not using shielded cable.

In applications where the wiring cable is installed in conduit, the conduit should not be used for wiring to other electrical equipment.

CAUTION

Installation of the detector and wiring should be performed only by qualified personnel.

PROTECTION AGAINST MOISTURE DAMAGE

It is important to take proper precautions during installation to ensure that moisture will not come in contact with the electrical connections of the system. The integrity of the system regarding moisture protection must be maintained for proper operation and is the responsibility of the installer.

If conduit is used, drains must be installed at water collection points to automatically drain accumulated moisture. Conduit breathers should be installed at upper locations to provide ventilation and allow water vapor to escape. At least one breather should be used with each drain.

Conduit raceways should be inclined so that water will flow to low points for drainage and will not collect inside enclosures or on conduit seals. If this is not possible, install conduit drains above the seals to prevent the collection of water or install a drain loop below the detector with a conduit drain at the lowest point of the loop.

Conduit seals may be required for compliance with explosion-proof installation requirements. Units with M25 thread must use an IP66 washer or an O-ring sealed adapter/gland to prevent water ingress.

WIRING PROCEDURE

Follow the instructions below to install the X9800.

1. Install the swivel mounting bracket assembly on the wall or instrument mount. The installation surface should be free of vibration and suitable to receive 1/4 inch (M6) screws with a length of at least 1 inch (25 mm). Refer to Figure 3 for dimensions.

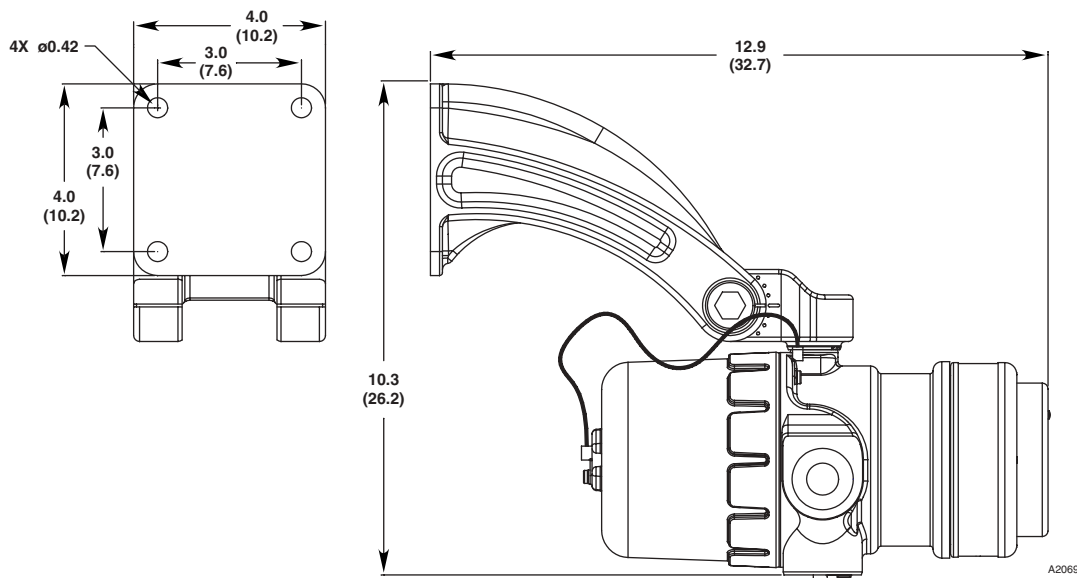

Figure 3—Q9033B Mounting Bracket Dimensions in Inches (cm)
(See Figure 1 for Correct Detector Orientation.)

2. Make field connections following local ordinances and guidelines in this manual. Refer to Figures 4 through 12.
3. Check all field wiring to be sure that the proper connections have been made.

IMPORTANT

Do not test any wiring connected to the detector with a meg-ohmmeter. Disconnect wiring at the detector before checking system wiring for continuity.

4. Make the final sighting adjustments and ensure that the mounting bracket hardware is tight.

9	4-20 mA +	19	4-20 mA -	SPARE	29
8	4-20 mA + REF	18	4-20 mA - REF	SPARE	28
7	COM FIRE	17		COM AUX	27
6	N.O. FIRE	16		N.O. AUX	26
5	N.C. FIRE	15		N.C. AUX	25
4	COM FAULT	14		RS-485 A	24
3	N.O. FAULT	13		RS-485 B	23
2	24 VDC +	12		MAN Oi	22
1	24 VDC -	11		24 VDC -	21

A2061

Figure 5—Wiring Terminal Identification

EOL RESISTORS

To ensure that the insulating material of the wiring terminal block will not be affected by the heat generated by EOL resistors, observe the following guidelines when installing the resistors.

1. Required EOL resistor power rating must be 5 watts minimum.
2. Resistor leads should be cut to a length of approximately 1 1/2 inches (40 mm).
3. Bend the leads and install the EOL resistor as shown in Figure 6.
4. Maintain a 3/8 inch (10 mm) minimum gap between the resistor body and the terminal block or any other neighboring parts.



Figure 4—X9800 Terminal Block

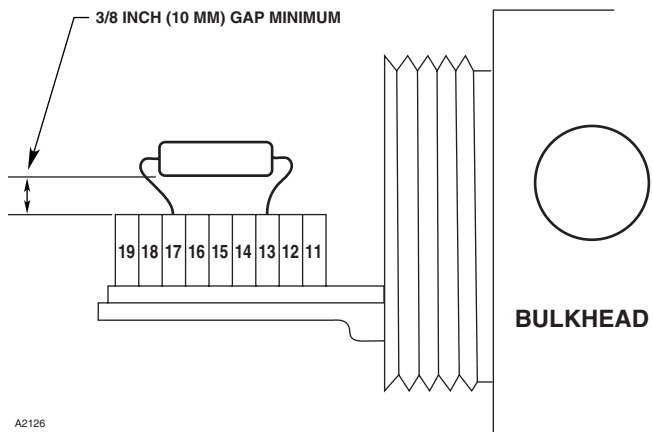

A2126

Figure 6—EOL Resistor Installation

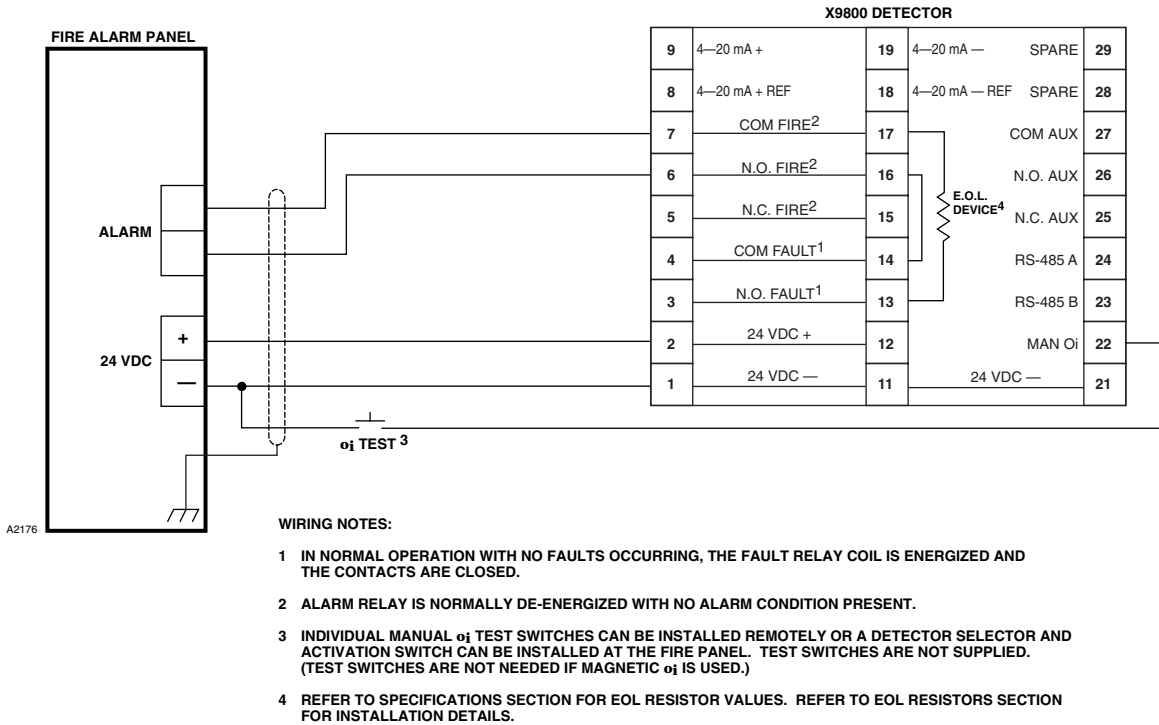

Figure 7—EEx d Wiring Option

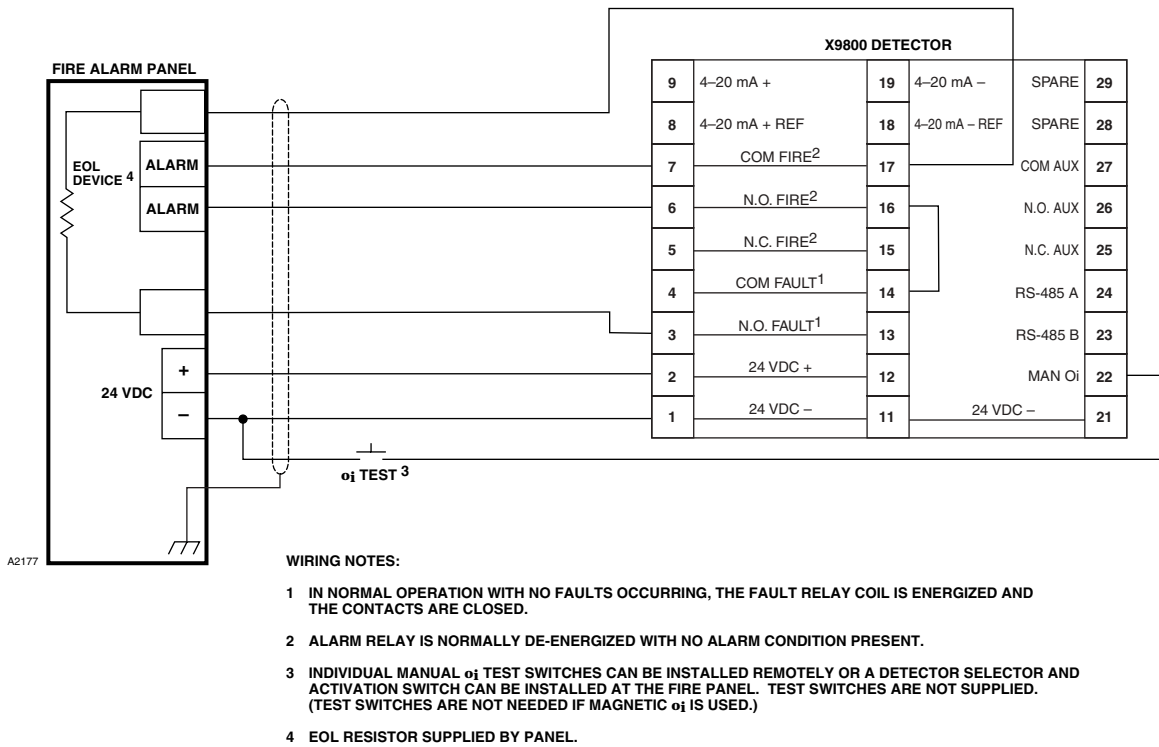

Figure 8—EEx e Wiring Option

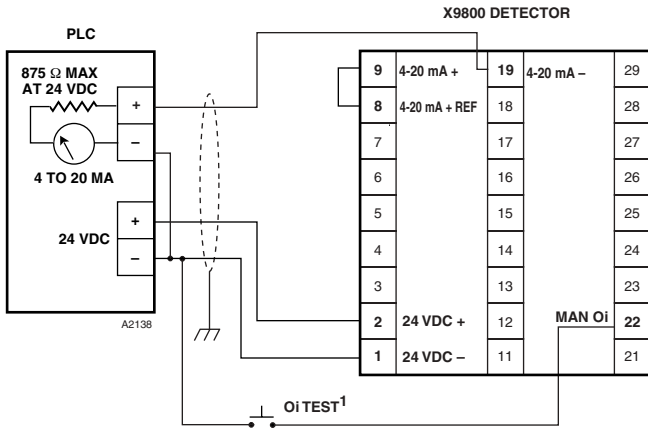

Figure 9—X9800 Detector Wired for Non-Isolated 4 to 20 ma Current Output (Sourcing)

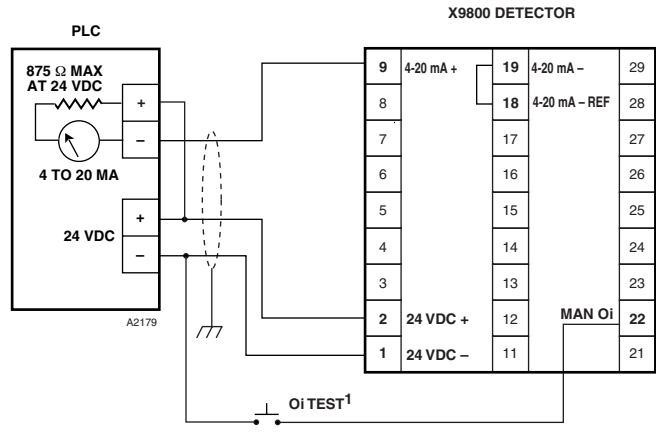

Figure 10—X9800 Detector Wired for Non-Isolated 4 to 20 ma Current Output (Sinking)

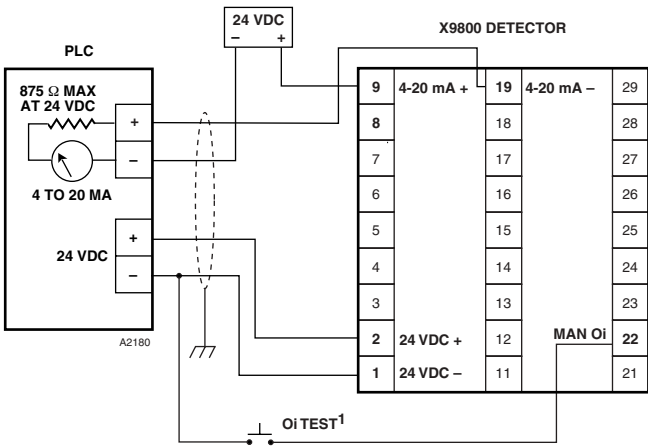

Figure 11—X9800 Detector Wired for Isolated 4 to 20 ma Current Output (Sourcing)

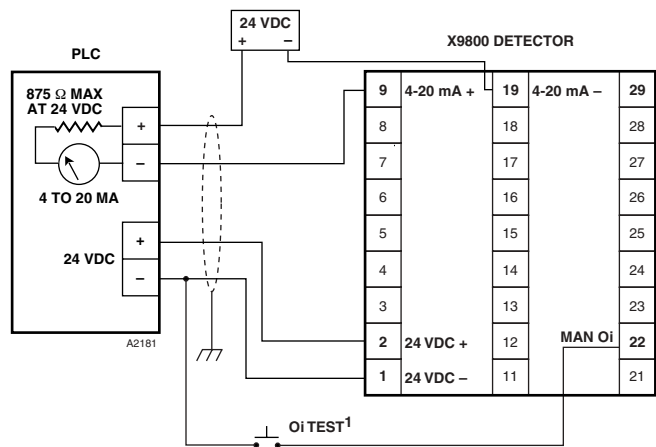

Figure 12—X9800 Detector Wired for Isolated 4 to 20 ma Current Output (Sinking)

NOTES: 1. INDIVIDUAL MANUAL oi TEST SWITCHES CAN BE INSTALLED REMOTELY OR A DETECTOR SELECTOR AND ACTIVATION SWITCH CAN BE INSTALLED AT THE FIRE PANEL. TEST SWITCHES ARE NOT SUPPLIED.

STARTUP PROCEDURE

When installation of the equipment is complete, perform the "Fire Alarm Test" below.

Allow 20 to 30 minutes for the detector's heated optics to reach equilibrium.

FIRE ALARM TEST

1. Disable any extinguishing equipment that is connected to the system.
2. Apply input power to the system.

3. Initiate an **oi** test. (See "Magnetic **oi** / Manual **oi**" under Optical Integrity in the Description section of this manual.)
4. Repeat this test for all detectors in the system. If a unit fails the test, refer to the "Troubleshooting" section.
5. Verify that all detectors in the system are properly aimed at the area to be protected. (The Det-Tronics Q1201C Laser Aimer is recommended for this purpose.)
6. Enable extinguishing equipment when the test is complete.

TROUBLESHOOTING

WARNING

The “front” half of the detector contains no user serviceable components and should not be opened. In the event of a malfunction, the entire sensor module must be returned to the factory for repair.

1. Disable any extinguishing equipment that is connected to the unit.
2. Inspect the viewing windows for contamination and clean as necessary. (Refer to the “Maintenance” section for complete information regarding cleaning of the detector viewing windows.)
3. Check input power to the unit.
4. Check system and detector logs and/or current output. See Table 3.
5. Turn off the input power to the detector and check all wiring for continuity. **Important:** Disconnect wiring at the detector before checking system wiring for continuity.
6. If all wiring checks out and cleaning of the **oi** plate/window did not correct the fault condition, check for high levels of background IR radiation by covering the detector with the factory supplied cover or aluminum foil. If the fault condition clears, extreme background IR radiation is present. Re-adjust the view of the detector away from the IR source or relocate the detector.

If none of these actions corrects the problem, return the detector to the factory for repair.

NOTE

It is highly recommended that a complete spare be kept on hand for field replacement to ensure continuous protection.

PERIODIC CHECKOUT PROCEDURE

A checkout of the system using the manual or magnetic **oi** feature should be performed on a regularly scheduled basis to ensure that the system is operating properly.

MAINTENANCE

IMPORTANT

Periodic flamepath inspections are not recommended, since the product is not intended to be serviced and provides proper ingress protection to eliminate potential deterioration of the flamepaths.

To maintain maximum sensitivity, the viewing windows of the X9800 must be kept relatively clean. Refer to the procedure below for cleaning instructions.

CLEANING PROCEDURE

CAUTION

Disable any extinguishing equipment that is connected to the unit to prevent unwanted actuation.

To clean the windows and **oi** plate, use Det-Tronics window cleaner (part number 001680-001) and a soft cloth, cotton swab or tissue and refer to the following procedure.

Table 3—Troubleshooting Guide

Current Level	Status	Action
0 mA	Open Circuit	Cycle power.
1 mA	General Fault	Check system wiring.
2 mA	Oi Fault	Clean windows.
4 mA	Normal Operation	
16 mA	Hi Background IR	Remove IR source or aim detector away from IR source.
20 mA	Fire Alarm	

1. **Disable any extinguishing equipment that is connected to the unit.**

NOTE

Remove input power when cleaning the detector windows. The rubbing motion on the surface of the windows during cleaning can create static electricity that could result in unwanted output activation.

2. To clean the optical surfaces, remove the **oi** plate following the procedure described below.
3. Thoroughly clean both viewing windows and reflective surfaces of the **oi** plate using a clean cloth, cotton swab or tissue, and Det-Tronics window cleaning solution. If a stronger solution is needed, isopropyl alcohol may be used.
4. Re-install the **oi** plate following the procedure described below.

oi PLATE REMOVAL

1. Loosen the two captive screws, then grasp the **oi** plate by the visor and remove it from the detector. See Figure 13.
2. Thoroughly clean the **oi** plate reflective surfaces, holding it by its edges to avoid leaving fingerprints on the inside reflective surface.
3. Re-install the **oi** plate. Ensure that the plate is flat on the detector surface. Tighten the **oi** plate screws securely (40 oz/inches).

NOTE

*If the **oi** plate is removed, be sure to install the original **oi** plate. **oi** plates are not interchangeable and should not be mixed with **oi** plates from other detectors. If corrosive contaminants in the atmosphere cause the **oi** plate surface to deteriorate to the extent that it is no longer possible to restore it to its original condition, it must be replaced. Consult factory for **oi** plate replacement procedure.*

CLOCK BATTERY

The real time clock has a backup battery that will operate the clock with no external power for nominally 10 years. It is recommended that the battery be replaced every 7 years.

FEATURES

- Responds to a fire in the presence of modulated blackbody radiation (i.e. heaters, ovens, turbines) without false alarm.
- High speed capability — 30 milliseconds.
- Built-in data logging / event monitoring, up to 1500 events (up to 1000 general, 500 alarms).
- Microprocessor controlled heated optics for increased resistance to moisture and ice.
- Automatic, manual or magnetic optical integrity (**oi**) testing.
- Easily replaceable **oi** plate.
- Fire, fault and auxiliary relays standard.
- 4 to 20 mA isolated output (optional).
- Tricolor LED indicates normal operation, fire and fault conditions.
- Operates under adverse weather conditions.
- Mounting swivel allows easy sighting.
- Integral wiring compartment for ease of installation.
- Explosion-proof/flame-proof detector housing. Meets FM, CSA, CENELEC (ATEX Directive Compliant) and CE certification requirements.
- Class A wiring per NFPA-72.
- Meets NFPA-33 response requirement for under 0.5 second (available when model selected).
- 3 year warranty.
- Advanced signal processing (ARC).
- RFI and EMC Directive Compliant.



Figure 13—Oi Plate Removal

SPECIFICATIONS

OPERATING VOLTAGE—

24 volts dc nominal (18 vdc minimum, 30 vdc maximum).

POWER CONSUMPTION—

Without heater: 2.1 watts at 24 vdc nominal;
3.5 watts at 24 vdc in alarm.
2.2 watts at 30 vdc nominal;
4.0 watts at 30 vdc in alarm.

Heater only: 8 watts maximum.

Total power: 16.5 watts at 30 vdc with EOL resistor installed and heater on maximum.

EOL resistor must be ceramic, wirewound type, rated 5 watts minimum, with actual power dissipation not to exceed 2.5 watts.

POWER UP TIME—

Fault indication clears after 0.5 second; device is ready to indicate an alarm condition after 30 seconds.

OUTPUT RELAYS—

Fire Alarm relay, Form C, 5 amperes at 30 vdc:

The Fire Alarm relay has redundant terminals and normally open / normally closed contacts, normally de-energized operation, and latching or non-latching operation.

Fault relay, Form A, 5 amperes at 30 vdc:

The Fault relay has redundant terminals and normally open contacts, normally energized operation, and latching or non-latching operation.

Auxiliary relay, Form C, 5 amperes at 30 vdc:

The auxiliary relay has normally open / normally closed contacts, normally energized or de-energized operation, and latching or non-latching operation.

CURRENT OUTPUT (Optional)—

4 to 20 milliampere dc current, with a maximum loop resistance of 500 ohms from 18 to 19.9 volts dc and 600 ohms from 20 to 30 volts dc.

TEMPERATURE RANGE—

Operating: -40°F to +167°F (-40°C to +75°C).

Storage: -67°F to +185°F (-55°C to +85°C).

Hazardous location ratings from -55°C to +75°C available on flameproof model.

HUMIDITY RANGE—

0 to 95% relative humidity, can withstand 100% condensing humidity for short periods of time.

CONE OF VISION—

The detector has a 90° cone of vision (horizontal) with the highest sensitivity lying along the central axis. See Figure 14.

100% REPRESENTS THE MAXIMUM DETECTION DISTANCE FOR A GIVEN FIRE. THE SENSITIVITY INCREASES AS THE ANGLE OF INCIDENCE DECREASES.

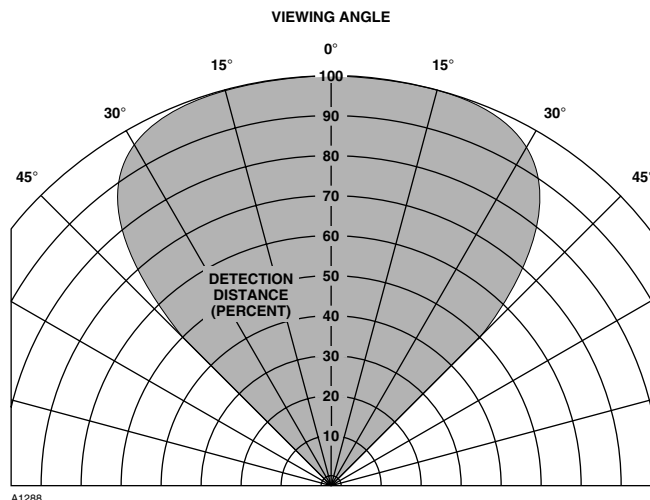

Figure 14—Detector Cone of Vision

RESPONSE TIME—

32 inch methane plume: < 10 seconds.

1 foot x 1 foot n-Heptane: < 15 seconds.

(See Appendix for details.)

ENCLOSURE MATERIAL—

Copper-free aluminum (red-painted) or 316 stainless steel.

DIMENSIONS—

See Figure 15.

WIRING—

12 AWG (2.5 mm²) to 22 AWG (0.3 mm²) shielded cable is recommended.

Important: 18 vdc minimum must be available at the detector. For ambient temperatures below -10°C and above +60°C use field wiring suitable for both minimum and maximum ambient temperature.

THREAD SIZE—

Conduit connection: 3/4 inch NPT or M25.

SHIPPING WEIGHT (Approximate)—

Aluminum: 6 pounds (2.7 kilograms).

Stainless Steel: 10 pounds (4.5 kilograms).

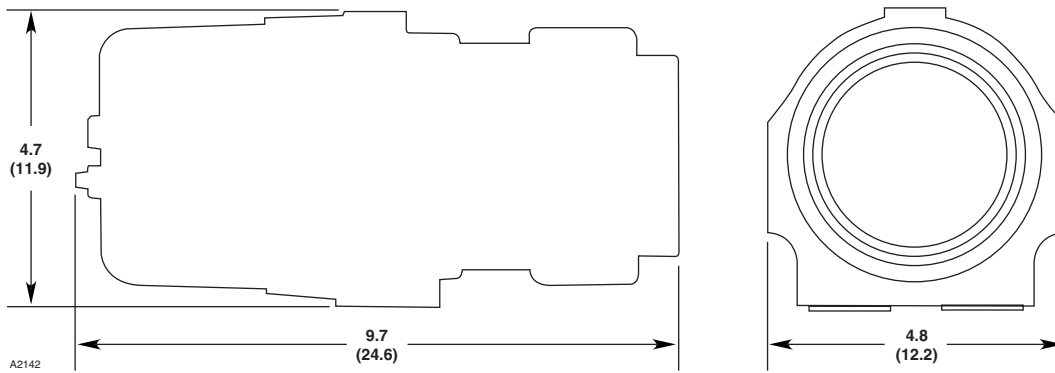

Figure 15—Dimensions in Inches (cm)

WARRANTY PERIOD—
3 years.

CERTIFICATION—



Class I, Div. 1, Groups B, C and D;
 Class II, Div. 1, Groups E, F, and G;
 Class I, Div. 2, Groups A, B, C and D (T3);
 Class II, Div. 2, Groups F and G (T3);
 Class III.
 Enclosure NEMA/Type 4X.

Increased Safety Model

0539 Ex II 2 GD
 EEx de IIC T5–T6 T86°C
 DEMKO 02 ATEX 132195
 T6 ($T_{\text{amb}} = -55^{\circ}\text{C}$ to $+60^{\circ}\text{C}$).
 T5 ($T_{\text{amb}} = -55^{\circ}\text{C}$ to $+75^{\circ}\text{C}$).
 IP66.

Flameproof Model

0539 Ex II 2 GD
 EEx d IIC T5–T6 T86°C
 DEMKO 02 ATEX 132195
 T6 ($T_{\text{amb}} = -55^{\circ}\text{C}$ to $+60^{\circ}\text{C}$).
 T5 ($T_{\text{amb}} = -55^{\circ}\text{C}$ to $+75^{\circ}\text{C}$).
 IP66.

NOTE

Operational performance verified from -40°C to $+75^{\circ}\text{C}$.

NOTE

Refer to “EOL Resistors” section for installation details. All cable entry devices and blanking elements shall be certified to “E-generation” or “ATEX” standards, in type of explosion protection increased safety “e” or flameproof enclosure “d” (as applicable), suitable for the conditions of use and correctly installed. They shall maintain the degree of ingress protection IP66 for the apparatus. Unused apertures shall be closed with suitable blanking elements.

REPLACEMENT PARTS

The detector is not designed to be repaired in the field. If a problem should develop, refer to the Troubleshooting section. If it is determined that the problem is caused by an electronic defect, the device must be returned to the factory for repair.

DEVICE REPAIR AND RETURN

Prior to returning devices, contact the nearest local Detector Electronics office so that a Service Order number can be assigned. A written statement describing the malfunction must accompany the returned device or component to expedite finding the cause of the failure.

Pack the unit properly. Use sufficient packing material in addition to an antistatic bag as protection from electrostatic discharge.

Return all equipment transportation prepaid to the factory in Minneapolis.

NOTE

It is highly recommended that a complete spare be kept on hand for field replacement to ensure continuous protection.

ORDERING INFORMATION

When ordering, please specify:

X9800 IR Flame Detector

Standard relay configuration is:

- Fire Relay Non-latching, De-energized;
- Auxiliary Relay Non-latching, Energized;
- Fault Relay Non-latching, Energized.

Consult the Factory for other relay configurations.

Specify **Enclosure Material:**

- Copper-free aluminum (red-painted)
- 316 stainless steel.

ACCESSORIES

Q9033B Swivel Mount Assembly is required for mounting the detector.

Q1116A Air Shield for use in dirty environments.

Q1201C Laser Aimer is recommended for verifying detector aiming.

Weather Shield is recommended for outdoor environments.

REPLACEMENT PARTS

Part Number	Description
001680-001	Window cleaner squeeze bottle (package of six bottles)
005003-001	Silicone-free grease

For assistance in ordering a system to fit your application, please contact:

Detector Electronics Corporation
6901 West 110th Street
Minneapolis, Minnesota 55438 USA
Operator: (952) 941-5665 or (800) 765-FIRE
Customer Service: (952) 946-6491
Fax: (952) 829-8750
E-mail: detronics@detronics.com

or contact your local sales office, which can be found on the Det-Tronics web site:

www.detronics.com

APPENDIX

Factory Mutual (FM) Approval Description and Performance Report

THE FOLLOWING ITEMS, FUNCTIONS AND OPTIONS DESCRIBE THE FM APPROVAL:

- Explosion-proof for Class I, Div. 1, Groups B, C and D Hazardous (Classified) Locations per FM 3615.
- Dust-ignition proof for Class II/III, Div. 1, Groups E, F and G Hazardous (Classified) Locations per FM 3615.
- Explosion-proof for Class I, Div. 2, Groups A, B, C and D (T3) Hazardous (Classified) Locations per FM 3611.
- Explosion-proof for Class II, Div. 2, Groups F and G (T3) Hazardous (Classified) Locations per FM 3611.
- Enclosure rating NEMA Type 4X per NEMA 250.
- Ambient Temperature Limits: -40°F to +167°F (-40°C to +75°C).
- Automatic Fire Alarm Signaling Performance verified per FM 3260 (2000).

The following performance criteria were verified:

OPTICAL INTEGRITY TEST:

The detector generated an optical fault in the presence of contamination on any single or combination of lens surfaces resulting in a loss of approximately half of its detection range, verifying that the detector performs a calibrated Automatic Optical Integrity (**oi**) test for the sensor. Upon removal of the contamination, the detector fault was cleared and the detector was verified to detect a fire.

The Manual / Magnetic **oi** performs the same calibrated test as the Automatic **oi**, and additionally actuates the alarm relay to verify output operation. If there is a loss of half of its detection range, an alarm signal is not generated.

Factory Mutual (FM) Approval Description and Performance Report – Continued

RESPONSE CHARACTERISTICS:

High Sensitivity

Fuel	Size	Distance (feet)	Typical Response Time (seconds)	TDSA	Quick Fire
n-Heptane	1 x 1 foot	50	8	On	Off
Methane	32 inch plume	35	3	On	Off
Pyrodex	40 grams	10	0.08	On	On
Black Powder	40 grams	10	0.04	On	On
n-Heptane	1 x 1 foot	50	6	On	On

Low Sensitivity

Fuel	Size	Distance (feet)	Typical Response Time (seconds)	TDSA	Quick Fire
n-Heptane	1 x 1 foot	15	8	On	Off

RESPONSE CHARACTERISTICS IN THE PRESENCE OF FALSE ALARM SOURCES:

High Sensitivity, TDSA On, Quick Fire Off

False Alarm Source	Distance (feet)	Fire Source	Distance (feet)	Typical Response Time (seconds)
Sunlight, direct, modulated/unmodulated	—	2 inch dia Heptane	10	< 30
Sunlight, reflected, modulated/unmodulated	—	2 inch dia Heptane	10	< 30
70 w sodium vapor lamp, unmodulated	5	2 inch dia Heptane	5	3
70 w sodium vapor lamp, modulated	5	2 inch dia Heptane	5	3
250 w mercury vapor lamp, unmodulated	5	2 inch dia Heptane	5	2
250 w mercury vapor lamp, modulated	5	2 inch dia Heptane	5	2.5
300 w incandescent lamp, unmodulated	5	2 inch dia Heptane	5	3
300 w incandescent lamp, modulated	5	2 inch dia Heptane	5	3
500 w shielded quartz halogen lamp, unmodulated	5	2 inch dia Heptane	5	2
500 w shielded quartz halogen lamp, modulated	5	2 inch dia Heptane	5	2
1500 w electric radiant heater, unmodulated	10	2 inch dia Heptane	5	3
1500 w electric radiant heater, modulated	10	2 inch dia Heptane	3	13
Two 34 w fluorescent lamps, unmodulated	3	2 inch dia Heptane	10	3
Two 34 w fluorescent lamps, modulated	3	2 inch dia Heptane	10	5

Factory Mutual (FM) Approval Description and Performance Report – Continued

FALSE ALARM IMMUNITY:

High Sensitivity, TDSA On, Quick Fire Off

False Alarm Source	Distance (feet)	Modulated Response	Unmodulated Response
Sunlight, direct, reflected	—	No alarm	No alarm
Vibration	N/A	No alarm	No alarm
Arc welding	15	No alarm	No alarm
70 w sodium vapor lamp	3	No alarm	No alarm
250 w mercury vapor lamp	3	No alarm	No alarm
300 w incandescent lamp	3	No alarm	No alarm
500 w shielded quartz halogen lamp	3	No alarm	No alarm
1500 w electric quartz heater	10	No alarm	No alarm
Two 34 w fluorescent lamps	3	No alarm	No alarm

FIELD OF VIEW:

High Sensitivity, TDSA On, Quick Fire Off

Fuel	Size	Distance (feet)	Horizontal (degrees)	Typical Horiz. Response Time (seconds)	Vertical (degrees)	Typical Vert. Response Time (seconds)
n-Heptane	1 x 1 foot	25	+45	7	+45	5.5
			-45	7	-30	4.5
Methane	32 inch plume	17.5	+45	6	+45	3.5
			-45	2.5	-30	4

High Sensitivity, TDSA On, Quick Fire On

Fuel	Size	Distance (feet)	Horizontal (degrees)	Typical Horiz. Response Time (seconds)	Vertical (degrees)	Typical Vert. Response Time (seconds)
Black Powder	40 Grams	5	+45	0.04	+45	0.04
			-45	0.03	-30	0.04