

# Instructions

**95-8576**

Protect•IR® Multispectrum IR Flame Detector  
X3302



# Table Of Contents

- DESCRIPTION ..... 1
  - Outputs ..... 2
  - LED ..... 2
  - Optical Integrity (**oi**) ..... 2
  - Communication ..... 3
  - Data Logging ..... 3
  - Integral Wiring Compartment ..... 3
- GENERAL APPLICATION INFORMATION ..... 3
  - Response Characteristics ..... 3
  - Important Application Considerations ..... 3
- IMPORTANT SAFETY NOTES ..... 4
- INSTALLATION ..... 4
  - Detector Positioning ..... 4
  - Detector Orientation ..... 5
  - Protection Against Moisture Damage ..... 5
  - Wiring Procedure ..... 6
  - Setting Device Network Addresses (EQP Model Only) ..... 12
- STARTUP PROCEDURE ..... 13
  - Fire Alarm Test ..... 13
- TROUBLESHOOTING ..... 13
- MAINTENANCE ..... 14
  - Cleaning Procedure ..... 14
  - oi** Plate Removal ..... 14
  - Periodic Checkout Procedure ..... 14
  - Clock Battery ..... 14
- FEATURES ..... 15
- SPECIFICATIONS ..... 15
- REPLACEMENT PARTS ..... 17
- DEVICE REPAIR AND RETURN ..... 17
- ORDERING INFORMATION ..... 17
  - Accessories ..... 17
- APPENDIX ..... 19

**Protect•IR®****Multispectrum IR Flame Detector****X3302****IMPORTANT**

*Be sure to read and understand the entire instruction manual before installing or operating the flame detection system. Any deviation from the recommendations in this manual may impair system performance and compromise safety.*

**ATTENTION**

*The X3302 includes the Automatic Optical Integrity (oi®) feature — a calibrated performance test that is automatically performed once per minute to verify complete detector operation capabilities. **No testing with an external test lamp is required.***

**DESCRIPTION**

The X3302 brings state-of-the-art IR flame detection to the difficult task of detecting invisible hydrogen flames. Focusing on the water-band IR emissions of hydrogen flame, the X3302 overcomes the limited detection range and false alarm tendencies of other flame detectors by employing field proven multispectrum infrared (MIR) technology. The result is unsurpassed flame sensitivity with discrimination of non-flame sources in situations where traditional flame detectors are unsuitable.

Utilizing the X3301's multi-patented\* signal processing algorithms, the X3302 provides a breakthrough in flame detection/surveillance of hazardous materials that produce mostly water vapor, and little or no CO<sub>2</sub> in the combustion process. The detection capability of the X3302 is double that of traditional UV and UVIR detectors. At the same time, it attains complete solar resistance and insensitivity to artificial lights, lightning, and "blackbody" radiation, which still plague other detection technologies.

X3302 technology advancements are covered under the following U.S. Patents: 5,995,008, 5,804,825 and 5,850,182.

The detector has Division and Zone explosion-proof ratings and is suitable for use in indoor and outdoor applications.

The standard output configuration includes fire, fault and auxiliary relays. Output options include:

- 4 to 20 mA output (in addition to the three relays)
- Pulse output for compatibility with existing controller based systems (with fire and fault relays)
- Eagle Quantum Premier (EQP) compatible model (no analog or relay outputs).

A multi-color LED on the detector faceplate indicates detector status condition.

Microprocessor controlled heated optics increase resistance to moisture and ice.

The X3302 housing is available in copper-free aluminum or stainless steel, with NEMA 4X and IP66 rating.

## OUTPUTS

### Relays

The standard detector is furnished with fire, fault and auxiliary relays. All three relays are rated 5 amperes at 30 VDC.

The Fire Alarm relay has redundant terminals and normally open / normally closed contacts, normally de-energized operation, and latching or non-latching operation.

The Fault relay has redundant terminals and normally open contacts, normally energized operation, and latching or non-latching operation.

The Auxiliary relay has normally open / normally closed contacts, and is configurable for energized or de-energized operation, and latching or non-latching operation.

### 4 to 20 mA Output

A 4 to 20 mA output is available as an option (in addition to the three relays). This option provides a 4 to 20 mA dc current output for transmitting detector status information to other devices. The circuit can be wired in either an isolated or non-isolated configuration and can drive a maximum loop resistance of 500 ohms from 18 to 19.9 volts dc and 600 ohms from 20 to 32 volts dc. Table 1 indicates the detector status conditions represented by the various current levels. The output is calibrated at the factory, with no need for field calibration. A model with relays and 4-20 mA with HART is also available. Refer to Addendum number 95-8613 for complete details.

#### NOTE

*The output of the 4 to 20 mA current loop is not monitored by the fault detection circuitry of the X3302. Therefore, an open circuit on the loop will not cause the fault relay to change state or the detector status LED to indicate a fault. The status of the LED always follows the status of the relays.*

Table 1—Detector Status Conditions Indicated by Current Level

Current Level ( $\pm 0.3$ mA)	Detector Status
0 mA	Power Fault
1 mA	General Fault
2 mA	<b>oi</b> Fault
3 mA	Hi Background IR
4 mA	Normal Operation
20 mA	Fire Alarm

An alarm condition will normally over-ride a fault condition, unless the nature of the fault condition impairs the ability of the detector to generate or maintain an alarm output, i.e. loss of operating power.

### LON/SLC Output

The EQP model is designed for use exclusively with the Det-Tronics Eagle Quantum Premier system. The detector communicates with the system controller over a digital communication network or LON/SLC (Local Operating Network / Signalling Line Circuit). The LON/SLC is a fault tolerant, two wire digital communication network arranged in a loop configuration. Analog and relay outputs are not available on this model.

### LED

A tricolor LED on the detector faceplate indicates normal, fire alarm and fault conditions. Table 2 indicates the condition of the LED for each status.

### OPTICAL INTEGRITY (O<sub>i</sub>)

#### Automatic o<sub>i</sub>

The X3302 includes the Automatic Optical Integrity (**oi**) feature — a calibrated performance test that is automatically performed once per minute to verify complete detector operation capabilities. No testing with an external test lamp is required. The detector automatically performs the same test that a maintenance person with a test lamp would perform — once every minute. However, a successful automatic **oi** test does not produce an alarm condition.

The Protect•IR® signals a fault condition when less than half of the detection range remains. This is indicated by the Fault relay and is evident by the amber color of the LED on the face of the detector. See the "Troubleshooting" section for further information.

Table 2—Detector Status Indicator

Detector Status	LED Indicator
Power On/Normal Operation (no fault or fire alarm)	Green
Fault	Amber
Fire (Alarm)	Red
Very High Sensitivity	Four Amber Flashes During Power-up

## Magnetic **o<sub>i</sub>** / Manual **o<sub>i</sub>**

The detector also incorporates both magnetic **o<sub>i</sub>** and manual **o<sub>i</sub>** features that provide the same calibrated test as the automatic **o<sub>i</sub>**, and in addition actuates the Alarm relay to verify output operation for preventive maintenance requirements. These features can be performed at any time and eliminate the need for testing with a non-calibrated external test lamp.

### CAUTION

*These tests require disabling of all extinguishing devices to avoid release resulting from a successful test.*

The magnetic **o<sub>i</sub>** test is performed by placing a magnet by the marked location (mag **o<sub>i</sub>**) on the outside of the detector. The manual **o<sub>i</sub>** test is accomplished by connecting the **o<sub>i</sub>** lead (terminal 22) to power supply minus via an external switch. The magnet or switch must be held in place for a minimum of 6 seconds to complete the test. Either of these test methods activates the calibrated IR emitters. If the resulting signal meets the test criteria, indicating that greater than half of the detection range remains, the Alarm relay changes state, the indicating LED changes to red, and the 4-20 mA current output goes to 20 mA. This condition remains until the magnet is removed or the switch is released, regardless of whether the relays are set for latching or non-latching operation

If less than half of the detection range remains, no alarm is produced and a fault is generated. The fault indication can be reset by momentarily applying the magnet or manual **o<sub>i</sub>** switch.

### NOTE

*Refer to the Appendix for FM verification of Det-Tronics' Optical Integrity **o<sub>i</sub>** function.*

## COMMUNICATION

The X3302 is furnished with an RS-485 interface for communicating status and other information with external devices. The RS-485 supports MODBUS protocol, with the detector configured as a slave device.

### NOTE

*The EQP model uses LON/SLC communication. RS-485 communication is not available on the EQP model.*

## DATA LOGGING

Data logging capability is also provided. Status conditions such as normal, power down, general and **o<sub>i</sub>** faults, pre-alarm, fire alarm, time and temperature are recorded. Each event is time and date stamped, along with the temperature and input voltage. Event data is stored in non-volatile memory when the event becomes active, and again when the status changes. Data is accessible using the RS-485 port or the EQP controller.

## INTEGRAL WIRING COMPARTMENT

All external wiring to the device is connected within the integral junction box. The screw terminals accept wiring from 14 to 24 AWG. The detector is furnished with four conduit entries, with either 3/4 inch NPT or 25 mm threads.

## GENERAL APPLICATION INFORMATION

### RESPONSE CHARACTERISTICS

Response is dependent on distance, type of fuel, temperature of the fuel, and time required for the fire to come to equilibrium. As with all fire tests, results must be interpreted according to an individual application. See Appendix for fire test results.

### IMPORTANT APPLICATION CONSIDERATIONS

In applying any type of sensing device as a fire detector, it is important to know of any conditions that can prevent the device from responding to fire, and also to know what other sources besides fire can cause the device to respond.

### Welding

Arc welding should not be performed within 20 feet of the detector. Gas welding mandates system bypass, since the gas torch is an actual fire. Arc welding rods can contain organic binder materials in the flux that burn during the welding operation and are detectable by the X3302. Welding rods with clay binders do not burn and will not be detected by the X3302. However, system bypass is always recommended, since the material being welded may be contaminated with organic substances (paint, oil, etc.) that will burn and possibly trigger the X3302.

### Artificial Lighting

The X3302 should not be located within 3 feet of artificial lights. Excess heating of the detector could occur due to heat radiating from the lights.

## EMI/RFI Interference

The X3302 is resistant to interference by EMI and RFI, and is EMC Directive compliant. It will not respond to a 5 watt walkie-talkie at distances greater than 1 foot. Do not operate a walkie-talkie within 1 foot of the X3302.

## Carbon Containing Fires

The X3302 is a multiple spectrum IR device with detection limited to flames that produce water vapor as a by-product of combustion. These include hydrogen, ammonia, arsine, silane, and light hydrocarbons such as methane and methanol. Some lighter carbonaceous fuels may be detectable by the X3302, but heavier carbon containing substances that burn with a dark yellow-orange flame and emit dense sooty smoke may not be sensed with this device. Other fuels that are not detectable include sulfur and burning metals.

## IMPORTANT SAFETY NOTES

### WARNING

*Do not open the detector assembly in a hazardous area when power is applied. The detector contains limited serviceable components and should never be opened. Doing so could disturb critical optical alignment and calibration parameters, possibly causing serious damage. This type of damage could be undetected and could result in failure to see a fire and/or false alarm.*

### CAUTION

*The wiring procedures in this manual are intended to ensure proper functioning of the device under normal conditions. However, because of the many variations in wiring codes and regulations, total compliance to these ordinances cannot be guaranteed. Be certain that all wiring complies with the NEC as well as all local ordinances. If in doubt, consult the authority having jurisdiction before wiring the system. Installation must be done by a properly trained person.*

### CAUTION

*To prevent unwanted actuation or alarm, extinguishing devices must be disabled prior to performing system tests or maintenance.*

### ATTENTION

*Remove the protective cap from the front of the detector before activating the system.*

### ATTENTION

*Observe precautions for handling electrostatic sensitive devices.*

## INSTALLATION

### DETECTOR POSITIONING

Detectors should be positioned to provide the best unobstructed view of the area to be protected. The following factors should also be taken into consideration:

- Identify all high risk fire ignition sources.
- Be sure that enough detectors are used to adequately cover the hazardous area.
- Be sure that the unit is easily accessible for cleaning and other periodic servicing.
- Locate and position the detector so that the fire hazard(s) are within both the field of view and detection range of the device. Refer to Appendix for specific information.
- Multispectrum IR detectors are less likely than other detectors to false alarm to non-flame infrared sources, as verified by the data shown in the "False Alarm Immunity" table (page 19) in the Appendix. However, in some instances, sustained modulation of these sources will cause a level of desensitization resulting in diminished detection range (refer to "Modulated Source" table [page 20] in the Appendix). For this reason, the X3302 should be sited/located to avoid these sources if there is likely to be frequent, sustained modulation of IR sources such as those shown. It is important to point out that these same sources have no effect on sensitivity if there is no modulation (refer to "Unmodulated Source" table [page 20] in the Appendix).
- The detector should be aimed downward at least 10 to 20 degrees to allow lens openings to drain. See Figure 1. **The detector should be positioned so that its field of view does not cover areas outside the hazardous area.** This will minimize the possibility of false alarms caused by activities outside the area requiring protection.
- For best performance, the detector should be mounted on a rigid surface in a low vibration area.
- Dense fog, rain or ice can absorb IR radiation and reduce the sensitivity of the detector.
- For ATEX installations, the X3302 detector housing must be electrically connected to earth ground.

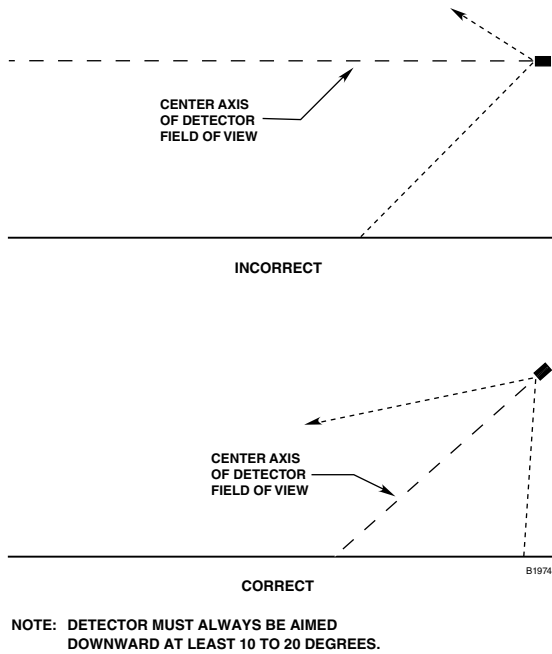

Figure 1—Detector Orientation Relative to Horizon

- Although IR detectors are less affected by smoke than other detectors, the X3302 should not be placed where rising combustion products can obscure its vision. If smoke is expected before fire, smoke or other alternative detectors should be used in conjunction with the X3302. For indoor applications, if dense smoke is expected to accumulate at the onset of a fire, mount the detector on a side wall at least a few feet (approximately 1 meter) down from the ceiling.
- If possible, fire tests should be conducted to verify correct detector positioning and coverage.

## DETECTOR ORIENTATION

Refer to Figure 2 and ensure that the **oi** plate will be oriented as shown when the X3302 is mounted and sighted. This will ensure proper operation of the **oi** system and will also minimize the accumulation of moisture and contaminants between the **oi** plate and the viewing windows. The **oi** plate includes an arrow, which should be pointed in the up direction, indicating that the **oi** plate and detector are correctly oriented.

### IMPORTANT

*The **oi** plate **must** be securely tightened to ensure proper operation of the **oi** system (40 oz./inches recommended).*

## PROTECTION AGAINST MOISTURE DAMAGE

It is important to take proper precautions during installation to ensure that moisture will not come in contact with the electrical connections or components of the system. The integrity of the system regarding moisture protection must be maintained for proper operation and is the responsibility of the installer.

If conduit is used, drains must be installed at water collection points to automatically drain accumulated moisture. Conduit breathers should be installed at upper locations to provide ventilation and allow water vapor to escape. At least one breather should be used with each drain.

Conduit raceways should be inclined so that water will flow to low points for drainage and will not collect inside enclosures or on conduit seals. If this is not possible, install conduit drains above the seals to prevent the collection of water or install a drain loop below the detector with a conduit drain at the lowest point of the loop.

Conduit seals are not required for compliance with explosion-proof installation requirements, but are highly recommended to prevent water ingress in outdoor applications. Units with M25 thread must use an IP66 washer to prevent water ingress.

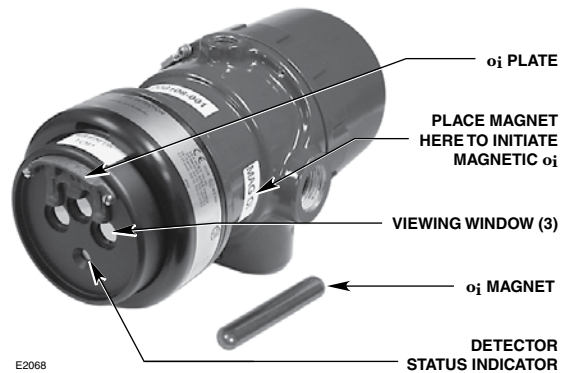

Figure 2—Front View of the X3302

## WIRING PROCEDURE

### Wire Size and Type

The system should be wired according to local codes. The wire size selected should be based on the number of detectors connected, the supply voltage and the cable length. Typically 14 AWG (2.08 mm<sup>2</sup>) or 16 AWG (1.31 mm<sup>2</sup>) shielded cable is recommended. Wires should be stripped 3/8 inch (9 mm). A minimum input voltage of 18 vdc must be present at the X3302.

#### NOTE

*Refer to "Power Consumption" in the "Specifications" section of this manual.*

The use of shielded cable is required to protect against interference caused by EMI and RFI. When using cables with shields, terminate the shields as shown in Figures 7 through 12, and Figure 14. Consult the factory if not using shielded cable.

In applications where the wiring cable is installed in conduit, the conduit must not be used for wiring to other electrical equipment.

If disconnection of power is required, separate disconnect capability must be provided.

#### CAUTION

*Installation of the detector and wiring should be performed only by qualified personnel.*

## Detector Mounting

Install the swivel mounting bracket assembly on the wall. The installation surface should be free of vibration and suitable to receive 1/4 inch (M6) screws with a length of at least 1 inch (25 mm), and have sufficient capacity to hold the detector and bracket weight. Refer to Figure 3 for dimensions.

## Relay and 4-20 mA Output Models

Follow the instructions below to install the X3302.

1. Make field connections following local ordinances and guidelines in this manual.
  - Figure 4 shows the wiring terminal strip located inside the detector's integral junction box.
  - Figure 5 shows the wiring terminal identification for the X3302 detector.
  - Figure 6 shows an EOL resistor installed within the integral wiring compartment of the detector (refer to "EOL Resistors" for details).
  - Figures 7 and 8 provide examples of typical installations with a X3302 wired to a fire alarm panel.
  - If the detector is equipped with a 4 to 20 mA output, refer to Figures 9 through 12.

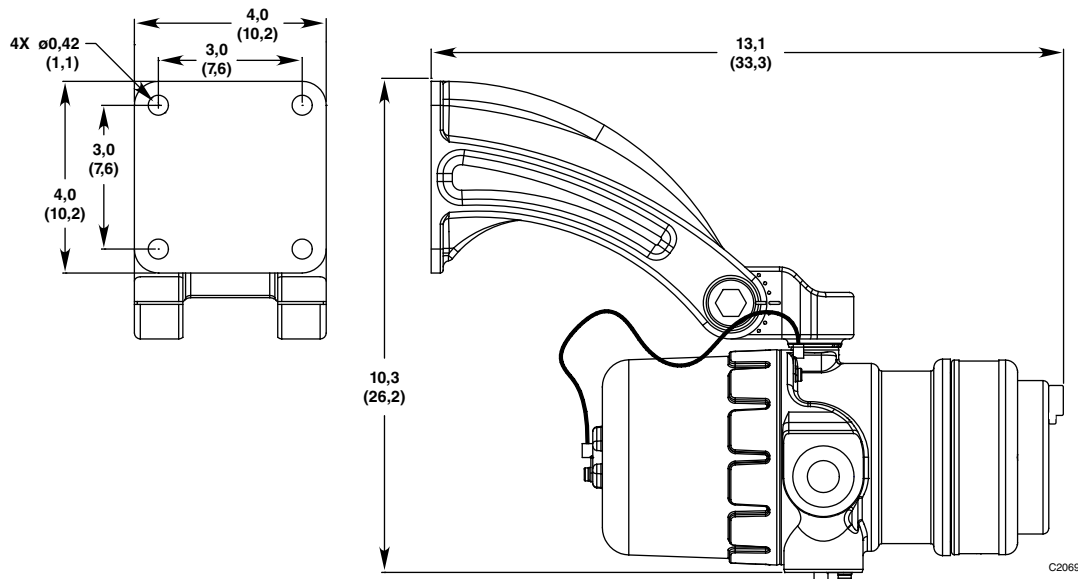

Figure 3—Q9033 Mounting Bracket Dimensions in Inches (cm)  
(See Figure 1 for Correct Detector Orientation.)



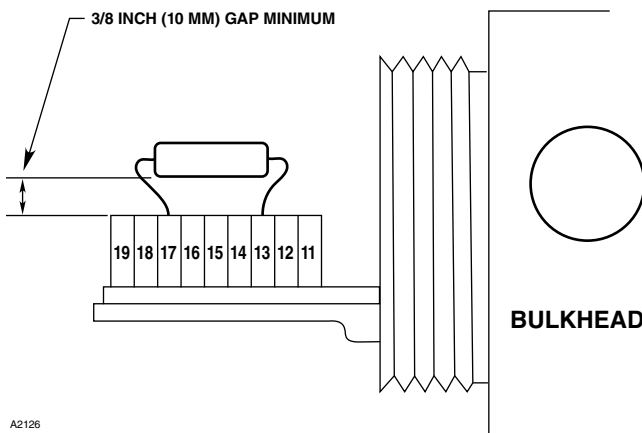

Figure 4—X3302 Terminal Block

9	4-20 mA +	19	4-20 mA -	SPARE	29
8	4-20 mA + REF	18	4-20 mA - REF	SPARE	28
7	COM FIRE	17	COM FIRE	COM AUX	27
6	N.O. FIRE	16	N.O. FIRE	N.O. AUX	26
5	N.C. FIRE	15	N.C. FIRE	N.C. AUX	25
4	COM FAULT	14	COM FAULT	RS-485 A	24
3	N.O. FAULT	13	N.O. FAULT	RS-485 B	23
2	24 VDC +	12	24 VDC +	MAN O <sub>i</sub>	22
1	24 VDC -	11	24 VDC -	24 VDC -	21

B2061

Figure 5—X3302 Wiring Terminal Identification



A2126

Figure 6—EOL Resistor Installation

2. Check all field wiring to be sure that the proper connections have been made.

### IMPORTANT

*Do not test any wiring connected to the detector with a meg-ohmmeter. Disconnect wiring at the detector before checking system wiring for continuity.*

3. Make the final sighting adjustments and ensure that the mounting bracket hardware is tight.

### EOL Resistors (Not Used with EQP Model)

To ensure that the insulating material of the wiring terminal block will not be affected by the heat generated by EOL resistors, observe the following guidelines when installing the resistors.

1. Required EOL resistor power rating must be 5 watts minimum.

### NOTE

*EOL resistors must be ceramic, wirewound type, rated 5 watts minimum, with actual power dissipation not to exceed 2.5 watts.*

2. Resistor leads should be cut to a length of approximately 1 1/2 inches (40 mm).
3. Bend the leads and install the EOL resistor as shown in Figure 6.
4. Maintain a 3/8 inch (10 mm) minimum gap between the resistor body and the terminal block or any other neighboring parts.

### NOTE

*All cable entry devices and blanking elements shall be certified to "E-generation" or "ATEX" standards, in type of explosion protection increased safety "e" or flameproof enclosure "d" (as applicable), suitable for the conditions of use and correctly installed. They shall maintain the degree of ingress protection IP66 for the apparatus. Unused apertures shall be closed with suitable blanking elements.*

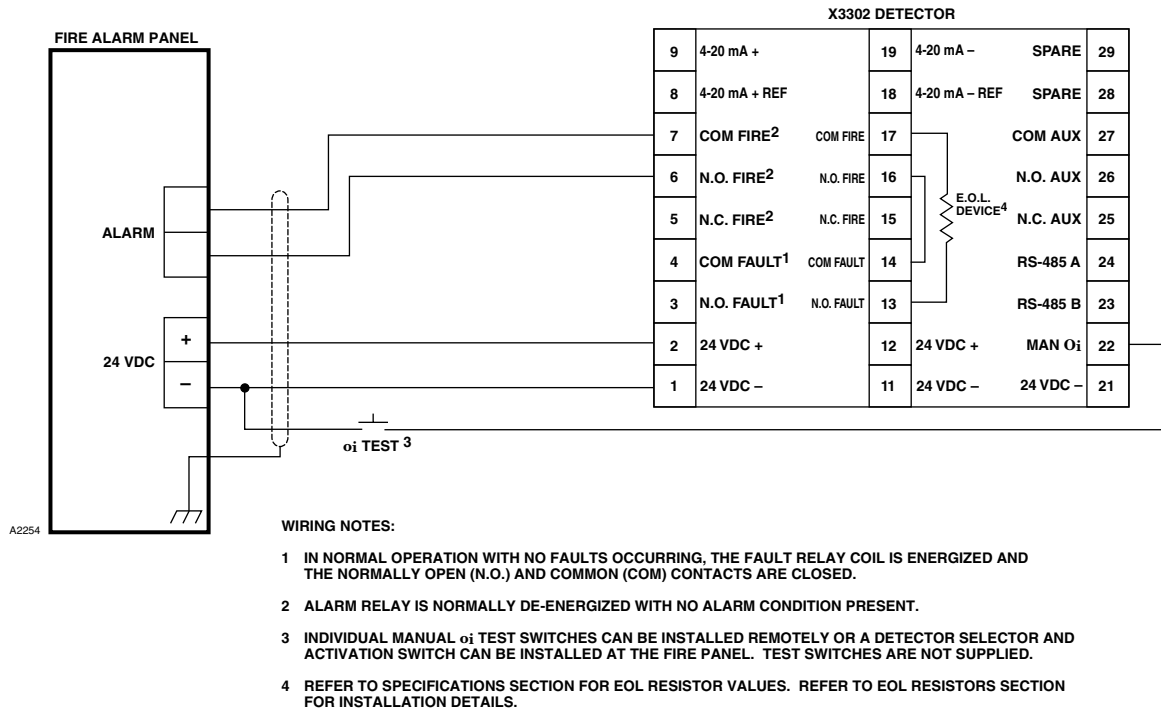

Figure 7—EEx d Wiring Option

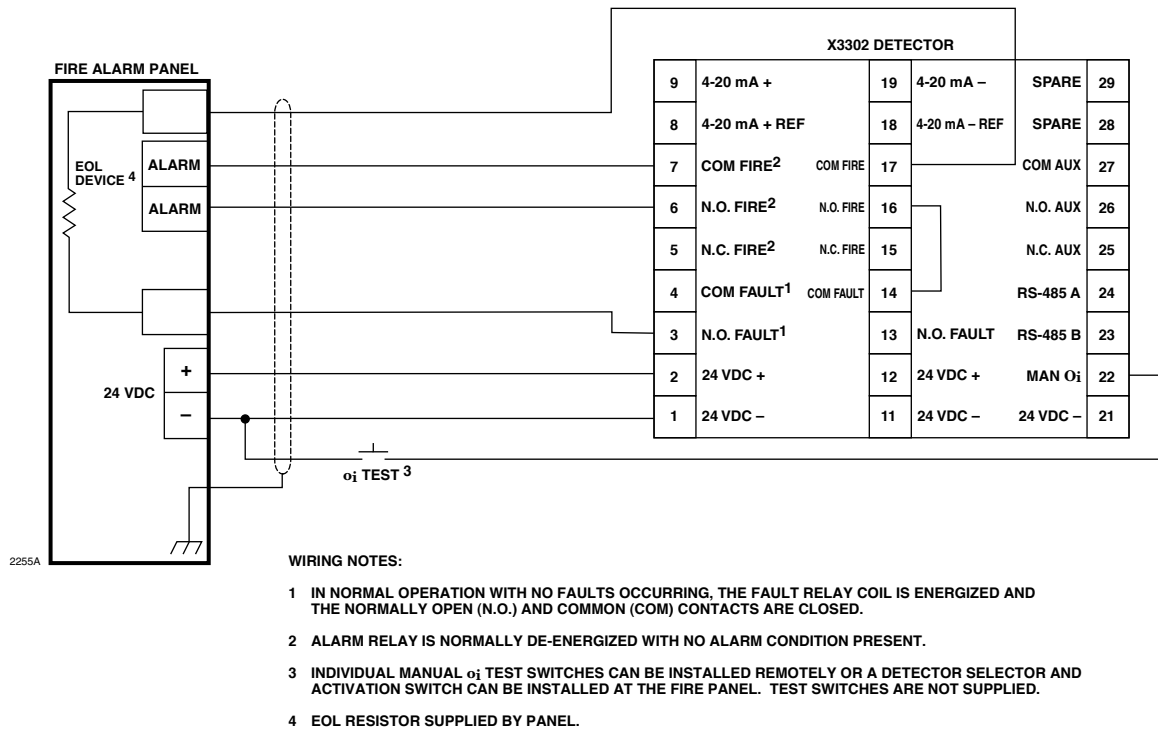

Figure 8—EEx e Wiring Option

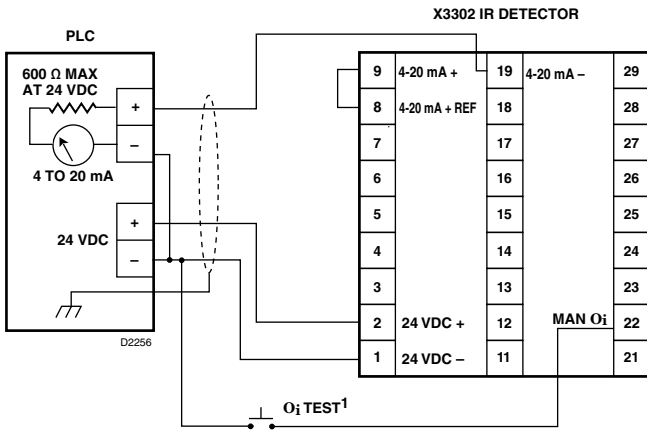

Figure 9—X3302 Detector Wired for Non-Isolated 4 to 20 mA Current Output (Sourcing)

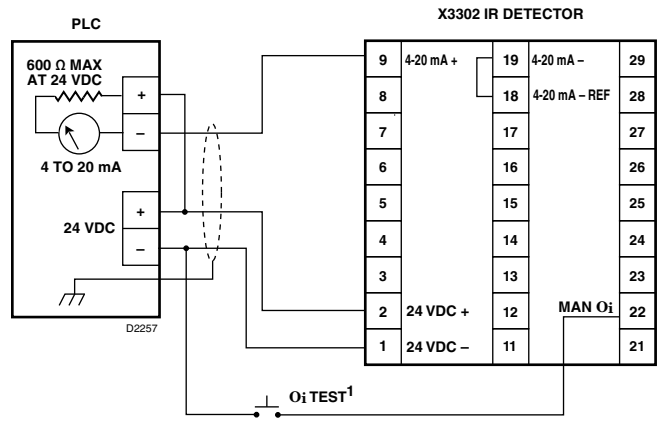

Figure 10—X3302 Detector Wired for Non-Isolated 4 to 20 mA Current Output (Sinking)

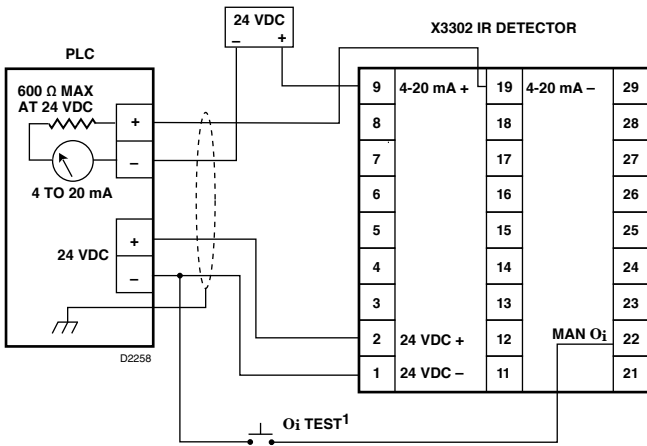

Figure 11—X3302 Detector Wired for Isolated 4 to 20 mA Current Output (Sourcing)

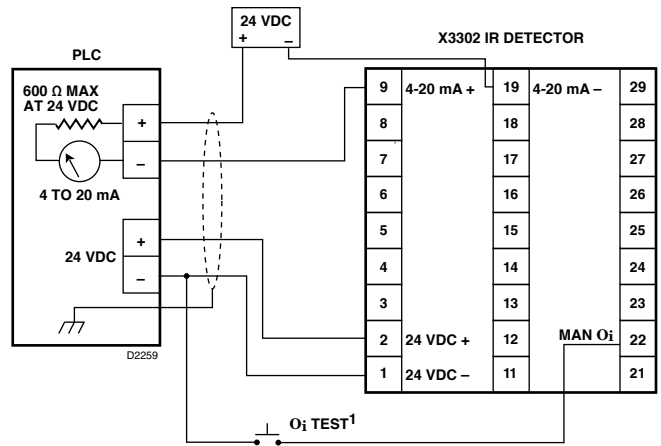

Figure 12—X3302 Detector Wired for Isolated 4 to 20 mA Current Output (Sinking)

**NOTES: 1. INDIVIDUAL MANUAL  $O_i$  TEST SWITCHES CAN BE INSTALLED REMOTELY OR A DETECTOR SELECTOR AND ACTIVATION SWITCH CAN BE INSTALLED AT THE FIRE PANEL. TEST SWITCHES ARE NOT SUPPLIED.**

**EQP Model**

1. Connect external wires to the appropriate terminals inside the device junction box. (See Figure 13 for terminal identification.)
2. Connect the shield of the power cable to “earth ground” at the power source.
3. Connect shields for the LON cable as indicated. See Figure 14.

**NOTE**

*DO NOT ground any shields at the detector housing.*

4. Set the device network address. (See “Setting Device Network Addresses” section of this manual for switch setting procedure.)

5. Check all field wiring to be sure that the proper connections have been made.
6. Replace the device cover.
7. Make the final sighting adjustments and ensure that the mounting bracket hardware is tight.

**NOTE**

*Refer to the Eagle Quantum Premier system manual (number 95-8533) for information regarding power and network communication cable requirements.*

COM SHIELD	6	16	COM SHIELD
COM 1 A	5	15	COM 2 A
COM 1 B	4	14	COM 2 B
POWER SHIELD	3	13	POWER SHIELD
24 VDC +	2	12	24 VDC +
24 VDC -	1	11	24 VDC -

A2089

Figure 13—Wiring Terminal Identification for X3302 EQP Model

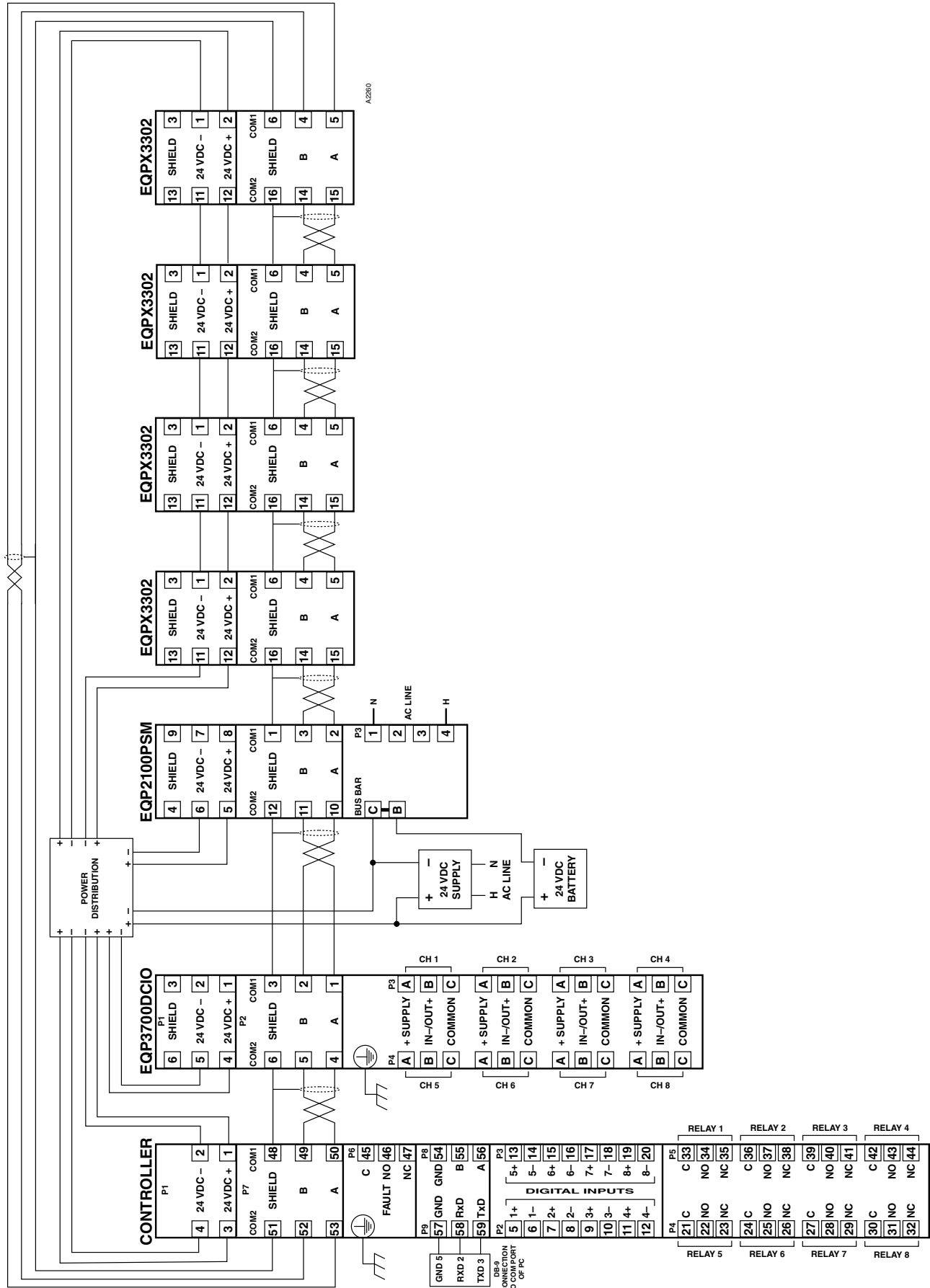

Figure 14—A Typical EQP System

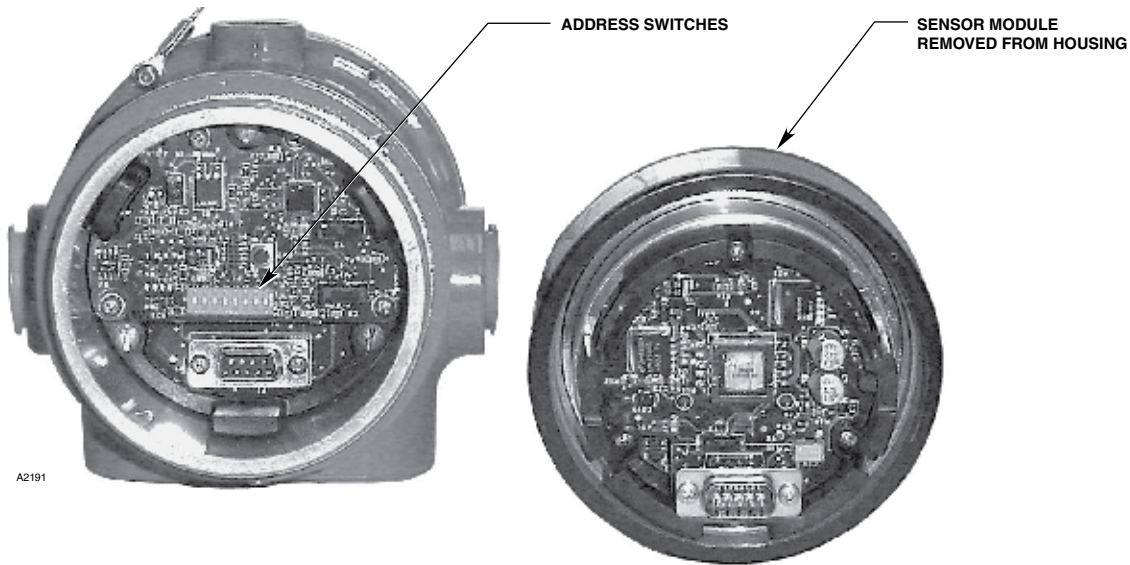

Figure 15—Location of Address Switches

## SETTING DEVICE NETWORK ADDRESSES (EQP Model Only)

### Overview of Network Addresses

Each device on the LON must be assigned a unique address. Addresses 1 to 4 are reserved for the controller. Valid addresses for field devices are from 5 to 250.

#### IMPORTANT

*If the address is set to zero or an address above 250, the switch setting will be ignored.*

Duplicated addresses are not automatically detected. Modules given the same address will use the number given and report to the controller using that address. The status word will show the latest update, which could be from any of the reporting modules using that address.

### Setting Field Device Addresses

Selection of the node address is done by setting rocker switches on an 8 switch “DIP Switch Assembly” within the detector’s housing. Refer to Figure 15 for switch location.

#### WARNING

*The network address switches are located within the detector housing. Disassembly of the detector head that contains powered electrical circuits is required to gain access to the network address switches. For hazardous areas, the area must be de-classified before attempting disassembly of the device. Always observe precautions for handling electrostatic sensitive devices.*

The address number is binary encoded with each switch having a specific binary value with switch 1 being the LSB (Least Significant Bit). (See Figure 16) The device’s LON address is equal to the added value of all closed rocker switches. All “Open” switches are ignored.

**Example:** for node No. 5, close rocker switches 1 and 3 (binary values 1 + 4); for node No. 25, close rocker switches 1, 4 and 5 (binary values 1 + 8 + 16).

#### NOTE

*The field device sets the LON address only when power is applied to the device. Therefore, it is important to set the switches **before** applying power. If an address is ever changed, system power must be cycled before the new address will take effect.*

After setting address switches, record the address number and device type.

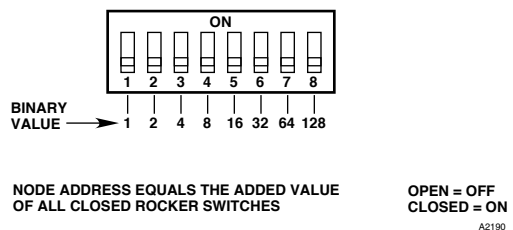

Figure 16—Address Switches for X3302

## STARTUP PROCEDURE

When installation of the equipment is complete, perform the “Fire Alarm Test” below.

Allow 20 to 30 minutes for the detector’s heated optics to reach equilibrium.

### FIRE ALARM TEST

1. Disable any extinguishing equipment that is connected to the system.
2. Apply input power to the system.
3. Initiate an **oi** test. (See “Magnetic **oi** / Manual **oi**” under Optical Integrity in the Description section of this manual.)
4. Repeat this test for all detectors in the system. If a unit fails the test, refer to the “Troubleshooting” section.
5. Verify that all detectors in the system are properly aimed at the area to be protected. (The Det-Tronics Q1201C Laser Aimer is recommended for this purpose.)
6. Enable extinguishing equipment when the test is complete.

## TROUBLESHOOTING

### WARNING

*The sensor module (“front” half of the detector) contains no user serviceable components and should never be opened. The terminal compartment is the only part of the enclosure that should be opened by the user in the field.*

1. Disable any extinguishing equipment that is connected to the unit.
2. Inspect the viewing windows for contamination and clean as necessary. The detector is relatively insensitive to airborne contaminants, however, thick deposits of ice, dirt, or oil will reduce sensitivity. (Refer to the “Maintenance” section for complete information regarding cleaning of the detector viewing windows.)

Table 3—Current Level Output Troubleshooting Guide

Current Level (±0.3 mA)	Status	Action
0 mA	Power Fault	Check System wiring
1 mA	General Fault	Cycle power. <sup>1</sup>
2 mA	<b>oi</b> Fault	Clean windows. <sup>2</sup>
3 mA	Hi Background IR	Remove IR source or aim detector away from IR source.
4 mA	Normal Operation	
20 mA	Fire Alarm	

<sup>1</sup>If fault continues, return device to factory for repair.

<sup>2</sup>See “Maintenance” section for cleaning procedure.

3. Check input power to the unit.
4. If the fire system has a logging function, check the fire panel log for output status information. See Table 3 for information regarding 4 to 20 mA output.
5. Turn off the input power to the detector and check all wiring for continuity. **Important: Disconnect wiring at the detector before checking system wiring for continuity.**
6. If all wiring checks out and cleaning of the **oi** plate/window did not correct the fault condition, check for high levels of background IR radiation by covering the detector with the factory supplied cover or aluminum foil. If the fault condition clears within 6 minutes or less, extreme background IR is present. Re-adjust the view of the detector away from the IR source or relocate the detector.

If none of these actions corrects the problem, return the detector to the factory for repair.

### NOTE

*It is highly recommended that a complete spare be kept on hand for field replacement to ensure continuous protection.*

## MAINTENANCE

### IMPORTANT

Periodic flamepath inspections are not recommended, since the product is not intended to be serviced and provides proper ingress protection to eliminate potential deterioration of the flamepaths.

### WARNING

The sensor module (“front” half of the detector) contains no user serviceable components and should never be opened. The terminal compartment is the only part of the enclosure that should be opened by the user in the field.

To maintain maximum sensitivity and false alarm resistance, the viewing windows of the X3302 must be kept relatively clean. Refer to the procedure below for cleaning instructions.

## CLEANING PROCEDURE

### CAUTION

Disable any extinguishing equipment that is connected to the unit to prevent unwanted actuation.

To clean the windows and **oi** plate, use Det-Tronics window cleaner (part number 001680-001) and a soft cloth, cotton swab or tissue and refer to the following procedure.

1. **Disable any extinguishing equipment that is connected to the unit.**
2. Since the X3302 is less affected by contamination than other detectors, removal of the **oi** plate is needed only under extreme conditions. In addition, it is not necessary to achieve perfect cleanliness, because IR is not significantly absorbed by slight films of oil and/or salt. If a fault condition is still indicated after cleaning, remove and clean the **oi** plate using the following procedure.
3. Clean all three viewing windows and reflector surfaces thoroughly using a clean cloth, cotton swab or tissue and Det-Tronics window cleaning solution. If a stronger solution is needed, isopropyl alcohol may be used.

## O<sub>i</sub> PLATE REMOVAL

1. Loosen the two captive screws, then grasp the **oi** plate by the visor and remove it from the detector. See Figure 17.

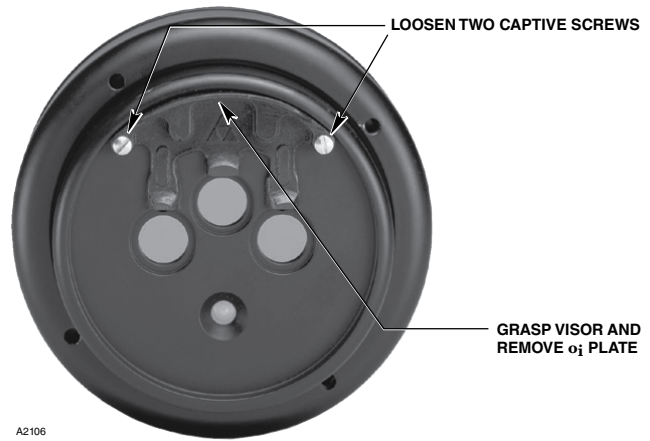

Figure 17—**oi** Plate Removal

2. Thoroughly clean the **oi** plate reflective surfaces, holding it by its edges to avoid leaving fingerprints on the inside reflective surface.
3. Re-install the **oi** plate. Ensure that the plate is flat on the detector surface. Tighten the **oi** plate screws securely (40 oz/inches).

### NOTE

If the **oi** plate is removed, be sure to install the original **oi** plate. **O<sub>i</sub>** plates are not interchangeable and should not be mixed with **oi** plates from other detectors. If corrosive contaminants in the atmosphere cause the **oi** plate surface to deteriorate to the extent that it is no longer possible to restore it to its original condition, it must be replaced. Consult factory for **oi** plate replacement procedure.

## PERIODIC CHECKOUT PROCEDURE

A checkout of the system using the manual or magnetic **oi** feature should be performed on a regularly scheduled basis to ensure that the system is operating properly. To test the system, perform the “Fire Alarm Test” as described in the “Startup Procedure” section of this manual.

## CLOCK BATTERY

The real time clock has a backup battery that will operate the clock with no external power for nominally 10 years. It is recommended that the battery be replaced every 7 years. Return the device to the factory for battery replacement.

### NOTE

If the backup battery is depleted, there is no effect on the operation of the flame detector, but the time stamping of the data log may be affected.



## FEATURES

- Unequaled false alarm rejection.
- Responds to a fire in the presence of modulated blackbody radiation (i.e. heaters, ovens, turbines) without false alarm.
- Microprocessor controlled heated optics for increased resistance to moisture and ice.
- Automatic, manual or magnetic optical integrity (**oi**) testing.
- Easily replaceable **oi** plate.
- Fire, fault and auxiliary relays standard.
- 4 to 20 mA isolated output (optional).
- Eagle Quantum Premier LON/SLC output (optional).
- Tricolor LED indicates normal operation, fire and fault conditions.
- Operates under adverse weather conditions and in dirty environments.
- Mounting swivel allows easy sighting.
- Integral wiring compartment for ease of installation.
- Explosion-proof/flame-proof detector housing. Meets FM, CSA, ATEX Directive and CE certification requirements.
- Class A wiring per NFPA-72.
- 5 year warranty.
- RFI and EMC Directive compliant.

## ASSOCIATED MANUALS

List of X3302 related manuals:

TITLE	FORM NUMBER
Pulse	95-8578
EQP	95-8533
HART Addendum	95-8613

## SPECIFICATIONS

### OPERATING VOLTAGE—

24 volts dc nominal (18 vdc minimum, 32 vdc maximum).  
Maximum ripple is 2 volts peak-to-peak.

### POWER CONSUMPTION—

Without heater: 4 watts at 24 vdc nominal;  
5.2 watts at 24 vdc in alarm.  
4.5 watts at 32 vdc nominal;  
6.5 watts at 32 vdc in alarm.

Heater only: 8 watts maximum.

Total power: 17 watts at 32 vdc with EOL resistor installed and heater on maximum.

EOL resistor must be ceramic, wirewound type, rated 5 watts minimum, with actual power dissipation not to exceed 2.5 watts.

For HART model, refer to Addendum number 95-8613.

### POWER UP TIME—

Fault indication clears after 0.5 second; device is ready to indicate an alarm condition after 30 seconds.

### OUTPUT RELAYS—

Fire Alarm relay, Form C, 5 amperes at 30 vdc:

The Fire Alarm relay has redundant terminals and normally open / normally closed contacts, normally de-energized operation, and latching or non-latching operation.

Fault relay, Form A, 5 amperes at 30 vdc:

The Fault relay has redundant terminals and normally open contacts, normally energized operation, and latching or non-latching operation.

Auxiliary relay, Form C, 5 amperes at 30 vdc:

The auxiliary relay has normally open / normally closed contacts, normally energized or de-energized operation, and latching or non-latching operation.

### CURRENT OUTPUT (Optional)—

4 to 20 milliampere ( $\pm 0.3$  mA) dc current, with a maximum loop resistance of 500 ohms from 18 to 19.9 volts dc and 600 ohms from 20 to 32 volts dc.

### LON OUTPUT (Optional)—

Digital communication, transformer isolated (78.5 kbps).

### TEMPERATURE RANGE—

Operating:  $-40^{\circ}\text{F}$  to  $+167^{\circ}\text{F}$  ( $-40^{\circ}\text{C}$  to  $+75^{\circ}\text{C}$ ).

Storage:  $-67^{\circ}\text{F}$  to  $+185^{\circ}\text{F}$  ( $-55^{\circ}\text{C}$  to  $+85^{\circ}\text{C}$ ).

Hazardous location ratings from  $-55^{\circ}\text{C}$  to  $+125^{\circ}\text{C}$ .

### HUMIDITY RANGE—

0 to 95% relative humidity, can withstand 100% condensing humidity for short periods of time.

### CONE OF VISION—

The detector has a  $90^{\circ}$  cone of vision (horizontal) with perfect cone of vision (full coverage at maximum detection distance, both on and off axis) for hydrogen and methanol flame detection.

Refer to Appendix for FM Approved cone of vision data.

### RESPONSE TIME—

Typical response times are under 10 seconds.

### ENCLOSURE MATERIAL—

Copper-free aluminum (red-painted) or 316 stainless steel.

### VIBRATION—

Conformance per FM 3260: 2000, MIL-STD 810C (Curve AW).

### DIMENSIONS—

See Figure 18.

**WIRING—**

Field wiring screw terminals are UL/CSA rated for up to 14 AWG wire, and are DIN/VDE rated for 2.5 mm<sup>2</sup> wire. Screw terminal required torque range is 3.5–4.4 in.-lbs. (0.4–0.5 N·m).

14 AWG (2.08 mm<sup>2</sup>) or 16 AWG (1.31 mm<sup>2</sup>) shielded cable is recommended.

**Important:** 18 vdc minimum must be available at the detector. For ambient temperatures below –10°C and above +60°C use field wiring suitable for both minimum and maximum ambient temperature.

**THREAD SIZE—**

Conduit connection: Four entries, 3/4 inch NPT or M25. Conduit seal not required.

**SHIPPING WEIGHT (Approximate)—**

Aluminum: 6 pounds (2.7 kilograms).  
 Stainless Steel: 10 pounds (4.5 kilograms).  
 Swivel Mount (AL): 6 pounds (2.75 kilograms).  
 Swivel Mount (SS): 14 pounds (6.4 kilograms).

**WARRANTY PERIOD—**

**5 years.**

**CERTIFICATION—**



Class I, Div. 1, Groups B, C and D;  
 Class II, Div. 1, Groups E, F, and G;  
 Class I, Div. 2, Groups A, B, C and D (T3C);  
 Class II, Div. 2, Groups F and G (T3C);  
 Class III.  
 Enclosure NEMA/Type 4X.

For complete FM certification details, refer to Appendix.



Increased Safety Model

CE 0539 Ⓢ II 2 GD  
 EEx de IIC T5–T6  
 DEMKO 04 ATEX 137104  
 T6 (T<sub>amb</sub> = –55°C to +60°C).  
 T5 (T<sub>amb</sub> = –55°C to +75°C).  
 IP66.

Flameproof Model

CE 0539 Ⓢ II 2 GD  
 EEx d IIC T4–T6  
 DEMKO 04 ATEX 137104  
 T6 (T<sub>amb</sub> = –55°C to +60°C).  
 T5 (T<sub>amb</sub> = –55°C to +75°C).  
 T4 (T<sub>amb</sub> = –55°C to +125°C).  
 IP66.

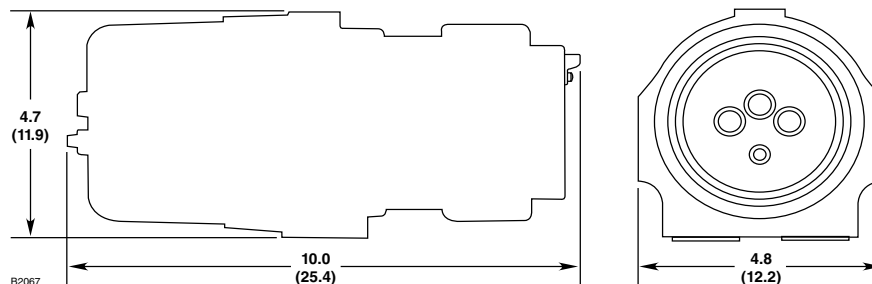

Figure 18—X3302 Dimensions in Inches (cm)

Conforms with: Low Voltage Directive (73/23/EEC).  
 Electromagnetic Compatibility Directive (89/336/EEC).  
 Explosive Atmosphere Directive (94/9/EC).

**NOTE**

*Operational performance verified from –40°C to +75°C.*

**NOTE**

*An optional third party addressable module can only be used within the EEx d flameproof model unless the addressable module is component certified as EEx e for use within the EEx d increased safety model.*

**NOTE**

*Refer to “EOL Resistors” section for installation details. All cable entry devices and blanking elements shall be certified to “E-generation” or “ATEX” standards, in type of explosion protection increased safety “e” or flameproof enclosure “d” (as applicable), suitable for the conditions of use and correctly installed. They shall maintain the degree of ingress protection IP66 for the apparatus. Unused apertures shall be closed with suitable blanking elements.*

**NOTE**

*For ATEX installations, the X3302 detector housing must be electrically connected to earth ground.*

**IECEX**

Certificate of Conformity  
 IECEX ULD 06.0017X  
 Ex d IIC T6 or Ex de IIC T6  
 T6 (T<sub>amb</sub> = –55°C to +60°C).

## REPLACEMENT PARTS

The detector is not designed to be repaired in the field. If a problem should develop, refer to the Troubleshooting section. If it is determined that the problem is caused by an electronic defect, the device must be returned to the factory for repair.

## DEVICE REPAIR AND RETURN

Prior to returning devices, contact the nearest local Detector Electronics office so that a Return Material Identification (RMI) number can be assigned. **A written statement describing the malfunction must accompany the returned device or component to assist and expedite finding the root cause of the failure.**

Pack the unit properly. Always use sufficient packing material. Where applicable, use an antistatic bag as protection from electrostatic discharge.

### NOTE

*Inadequate packaging that ultimately causes damage to the returned device during shipment will result in a service charge to repair the damage incurred during shipment.*

Return all equipment transportation prepaid to the factory in Minneapolis.

### NOTE

*It is highly recommended that a complete spare be kept on hand for field replacement to ensure continuous protection.*

## ORDERING INFORMATION

When ordering, please specify:

X3302 IR Flame Detector

Refer to the X3302 Model Matrix for details

Q9033 mount is required:

Q9033A for aluminum detectors only.

Q9033B for aluminum and stainless steel detectors.

## X-SERIES FLAME DETECTOR ACCESSORIES

Part Number	Description
000511-029	Converter RS485 to RS232
001680-001	Window cleaner (6 pack)
005003-001	1 oz grease for detectors (non-silicon)
006097-001	Q1201 Laser
007240-001	Q1116A1001, Air Shield (AL)
007255-001	Q1201C1001 X-Series Laser Holder (AL/Plastic)
007290-001	Q9033B Stainless Steel Swivel Mount Assembly is for aluminum and stainless steel detectors
007290-002	Q9033A Aluminum Swivel Mount Assembly is for aluminum detectors only
007307-001	<b>oi</b> plate for X3301 (requires inspector connector to calibrate)
007307-002	<b>oi</b> plate for X52/X22/X98 (requires inspector connector to calibrate)
007307-003	<b>oi</b> plate for X3302 (requires inspector connector to calibrate)
007338-001	Q2000A1001 X-Series Weather Shield (AL)
007338-010	Q2033A10R X3301/X3302 FOV Limiter 10° (AL)
007338-020	Q2033A20R X3301/X3302 FOV Limiter 20° (AL)
007338-030	Q2033A30R X3301/X3302 FOV Limiter 30° (AL)
007739-001	Magnet and Extension Pole
007818-001	Q1118A1001 Aluminum Air Shield/Flange Mount (AL)
007818-002	Q1118S1001 Stainless Steel Air Shield/Flange Mount (SS)
007819-001	W6300B1002 Inspector Connector (Inspector Monitor software included)
007912-010	Spare Restrictor Plate 10° (AL)
007912-020	Spare Restrictor Plate 20° (AL)
007912-030	Spare Restrictor Plate 30° (AL)
009177-001	Q1120A1001 Paint shield mounting ring (AL)
009199-001	Q1198A1001 Dual Air Shield/Flange Mount (X9800 only)/(AL)
009207-001	Inspector Monitor CD
009208-001	<b>oi</b> kit (5 plates) with Inspector Connector and Monitor X3301
009208-002	<b>oi</b> kit (5 plates) with Inspector Connector and Monitor X52/X22/X98
101197-003	Stop Plug, SS, IP66, EEx de, M25 (SS)
102740-002	Magnet
102871-001	Laser Battery, 3V Lithium (laser)
103922-001	Model 475 HART Communicator
103363-001	14mm Hex Wrench (Steel)
103406-001	Screwdriver
103517-001	Stop Plug, AL, IP66, EEx de, M25 (AL)
107427-040	O-ring - Rear Cover (Viton)

**X3302 MODEL MATRIX**

MODEL	DESCRIPTION	
<b>X3302</b>	Multispectrum IR Flame Detector	
	TYPE	MATERIAL
	<b>A</b>	Aluminum
	<b>S</b>	Stainless Steel (316)
	TYPE	THREAD TYPE
	<b>4M</b>	4 PORT, METRIC M25
	<b>4N</b>	4 PORT, 3/4" NPT
	TYPE	OUTPUTS
	<b>13</b>	Relay and 4-20 mA
	<b>14</b>	Eagle Quantum Premier
	<b>15</b>	Relay and Pulse
	<b>16</b>	Addressable Module Only (Third Party Type)
	<b>23</b>	Relay, 4-20 mA and HART
	TYPE	APPROVAL AGENCY
	<b>W</b>	FM/CSA/ATEX/CE
	TYPE	CLASSIFICATION*
	<b>1</b>	Division/Zone Ex de
	<b>2</b>	Division/Zone Ex d

\*Detectors are always Class I, Div. 1.

# APPENDIX

## FM Approvals Description and Performance Report

THE FOLLOWING ITEMS, FUNCTIONS AND OPTIONS DESCRIBE THE FM APPROVAL:

- Explosion-proof for Class I, Div. 1, Groups B, C and D Hazardous (Classified) Locations per FM 3615.
- Dust-ignition proof for Class II/III, Div. 1, Groups E, F and G Hazardous (Classified) Locations per FM 3615.
- Explosion-proof for Class I, Div. 2, Groups A, B, C and D (T3C) Hazardous (Classified) Locations per FM 3611.
- Explosion-proof for Class II, Div. 2, Groups F and G (T3C) Hazardous (Classified) Locations per FM 3611.
- Enclosure rating NEMA/Type 4X per NEMA 250.
- Ambient Temperature Limits:  $-40^{\circ}\text{F}$  to  $+167^{\circ}\text{F}$  ( $-40^{\circ}\text{C}$  to  $+75^{\circ}\text{C}$ ).
- Automatic Fire Alarm Signaling Performance verified per FM 3260 (2000).

### NOTE

*Actual response times of the EQP Model may vary.*

The following performance criteria were verified:

#### **OPTICAL INTEGRITY TEST:**

The detector generated an optical fault in the presence of contamination on any single or combination of lens surfaces resulting in a loss of approximately 50% of its detection range, verifying that the detector performs a calibrated Automatic Optical Integrity (**oi**) test for each sensor. Upon removal of the contamination, the detector fault was cleared and the detector was verified to detect a fire.

The Manual / Magnetic **oi** performs the same calibrated test as the Automatic **oi**, and additionally actuates the alarm relay to verify output operation. If there is a 50% loss of its detection range, an alarm signal is not generated.

## FM Approvals Description and Performance Report – Continued

### RESPONSE CHARACTERISTICS:

#### Very High Sensitivity

Fuel	Size / Flow Rate	Distance feet (m)	Avg. Horiz. Response Time (seconds)
Hydrogen	24inch plume/100 SLPM*	100 (30.5)	2
Methanol	1 x 1 foot	70 (21.3)	2

\*Standard Liters Per Minute (Standard conditions defined as +25°C and 14.696 PSIA)

### FIELD OF VIEW:

#### Very High Sensitivity

Fuel	Size/ Flow Rate	Distance feet (m)	Horizontal (degrees)	Avg. Horiz. Response Time (seconds)	Vertical (degrees)	Avg. Vert. Response Time (seconds)
Hydrogen	24inch plume/ 100 SLPM	100 (30.5)	+45	4	+45	3
			-45	3	-30	3
Methanol	1 x 1 foot	70 (21.3)	+45	2	+45	2
			-45	3	-30	2

#### **NOTE**

*Refer to the “High Resolution Field of View” charts (page 22) for additional information.*

### FALSE ALARM IMMUNITY:

#### Very High Sensitivity

False Alarm Source	Distance feet (m)	Modulated Response	Unmodulated Response
Sunlight, direct	—	No alarm	No alarm
Sunlight, reflected	—	No alarm	No alarm
Vibration	N/A	N/A	N/A
Arc welding	20 (6)	No alarm	No alarm
70 w sodium vapor lamp	10 (3)	No alarm	No alarm
250 w mercury vapor lamp	10 (3)	No alarm	No alarm
300 w incandescent lamp	10 (3)	No alarm	No alarm
500 w shielded quartz halogen lamp	15 (5)	No alarm	No alarm
1500 w electric quartz heater	10 (3)	No alarm	No alarm
Two 34 w fluorescent lamps	5 (1.5)	No alarm	No alarm

**FM Approvals Description and Performance Report – Continued**

**RESPONSE CHARACTERISTICS IN THE PRESENCE OF FALSE ALARM SOURCES:**

**Very High Sensitivity**

**Unmodulated Source**

<b>False Alarm Source Unmodulated</b>	<b>Distance feet (m)</b>	<b>Fire Source</b>	<b>Distance feet (m)</b>	<b>Average Response Time (seconds)</b>
Two 34 w fluorescent lamps	5 (1.5)	100 SLPM	100 (30.5)	2
70 w sodium vapor	10 (3)	100 SLPM	100 (30.5)	2
Arc welding, #7014	20 (6.1)	100 SLPM	100 (30.5)	6
250 w vapor lamp	10 (3)	100 SLPM	100 (30.5)	2
300 w incandescent lamp	10 (3)	100 SLPM	100 (30.5)	2
1500 w electric radiant heater	10 (3)	100 SLPM	100 (30.5)	2
500 w shielded quartz halogen lamp	15 (4.6)	100 SLPM	100 (30.5)	3
Sunlight, direct*	—	50 SLPM	50 (15.2)	2
Sunlight, direct*	—	100 SLPM	50 (15.2)	2

\*Outdoor test conditions.

**Modulated Source**

<b>False Alarm Source Modulated</b>	<b>Distance feet (m)</b>	<b>Fire Source Hydrogen</b>	<b>Distance feet (m)</b>	<b>Average Response Time (seconds)</b>
Two 34 w fluorescent lamps	5 (1.5)	100 SLPM	100 (30.5)	3
70 w sodium vapor	10 (3)	100 SLPM	100 (30.5)	2
Arc welding, #7014	20 (6.1)	100 SLPM	70 (21.3)	6
250 w vapor lamp	10 (3)	100 SLPM	70 (21.3)	5
300 w incandescent lamp	10 (3)	100 SLPM	60 (18.3)	2
1500 w electric radiant heater	10 (3)	100 SLPM	40 (12.2)	5
500 w shielded quartz halogen lamp	15 (4.6)	100 SLPM	35 (10.7)	11
Sunlight, reflected*	—	100 SLPM	20 (6.1)	5
Sunlight, direct*	—	200 SLPM	15 (4.6)	14

\*Outdoor test conditions.

FM Approvals Description and Performance Report – Continued

HIGH RESOLUTION FIELD OF VIEW

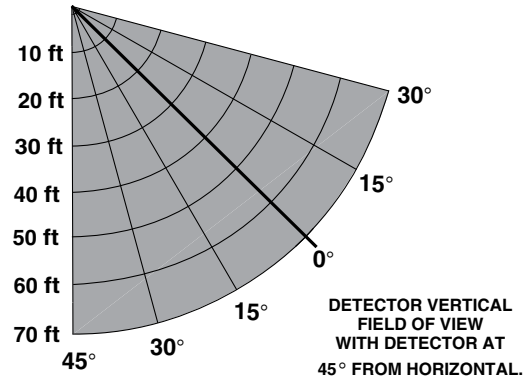
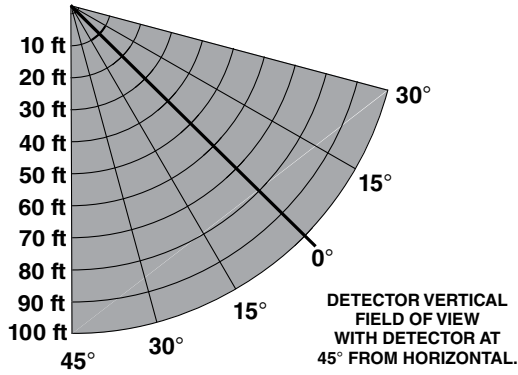
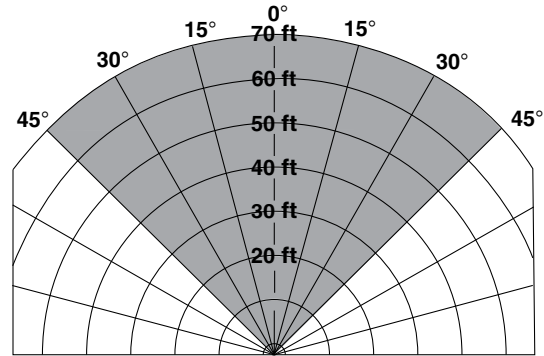
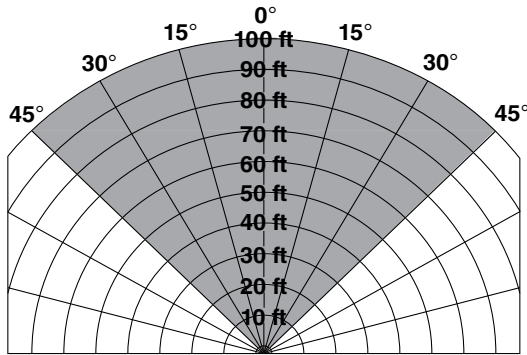

Field of View at Indicated Distance in Feet for **Hydrogen** at **Very High** Sensitivity (24 inch plume, with 100 SLPM flow rate)

Field of View at Indicated Distance in Feet for **Methanol** at **Very High** Sensitivity (1 x 1 ft)

**NOTE**

*FM Approvals minimum requirements are response distance measurements at 0° (on axis) and the limits of the field of view. These high resolution field of view diagrams show the measured response distances at all the indicated angles in the horizontal plane.*





95-8576



X3301 Multispectrum  
IR Flame Detector



PointWatch Eclipse®  
IR Combustible Gas Detector



FlexVu® Universal Display  
w/ GT3000 Toxic Gas Detector



Eagle Quantum Premier®  
Safety System

Detector Electronics Corporation  
6901 West 110th Street  
Minneapolis, MN 55438 USA

T: 952.941.5665 or 800.765.3473

F: 952.829.8750

W: <http://www.det-tronics.com>

E: [det-tronics@det-tronics.com](mailto:det-tronics@det-tronics.com)



A UTC Fire & Security Company

Det-Tronics, the DET-TRONICS logo, Protect•IR, and Automatic Optical Integrity (o.i.) are registered trademarks or trademarks of Detector Electronics Corporation in the United States, other countries, or both. Other company, product, or service names may be trademarks or service marks of others.

© Copyright Detector Electronics Corporation 2010. All rights reserved